



## NRC Publications Archive Archives des publications du CNRC

### **Development of Non-Destructive Condition Monitoring Techniques for Low-Voltage Cables**

Guérout, F.; Cissé, L.; Boor, R.; Blouin, A.

This publication could be one of several versions: author's original, accepted manuscript or the publisher's version. / La version de cette publication peut être l'une des suivantes : la version prépublication de l'auteur, la version acceptée du manuscrit ou la version de l'éditeur.

#### **Publisher's version / Version de l'éditeur:**

*Proceedings of the 8th International Conference on CANDU Maintenance, 2008, 2009-01-01*

#### **NRC Publications Record / Notice d'Archives des publications de CNRC:**

<https://nrc-publications.canada.ca/eng/view/object/?id=7f2dac94-48e7-4134-b885-1262f29a30bc>  
<https://publications-cnrc.canada.ca/fra/voir/objet/?id=7f2dac94-48e7-4134-b885-1262f29a30bc>

Access and use of this website and the material on it are subject to the Terms and Conditions set forth at

<https://nrc-publications.canada.ca/eng/copyright>

READ THESE TERMS AND CONDITIONS CAREFULLY BEFORE USING THIS WEBSITE.

L'accès à ce site Web et l'utilisation de son contenu sont assujettis aux conditions présentées dans le site

<https://publications-cnrc.canada.ca/fra/droits>

LISEZ CES CONDITIONS ATTENTIVEMENT AVANT D'UTILISER CE SITE WEB.

**Questions?** Contact the NRC Publications Archive team at [PublicationsArchive-ArchivesPublications@nrc-cnrc.gc.ca](mailto:PublicationsArchive-ArchivesPublications@nrc-cnrc.gc.ca). If you wish to email the authors directly, please see the first page of the publication for their contact information.

**Vous avez des questions?** Nous pouvons vous aider. Pour communiquer directement avec un auteur, consultez la première page de la revue dans laquelle son article a été publié afin de trouver ses coordonnées. Si vous n'arrivez pas à les repérer, communiquez avec nous à [PublicationsArchive-ArchivesPublications@nrc-cnrc.gc.ca](mailto:PublicationsArchive-ArchivesPublications@nrc-cnrc.gc.ca).



# DEVELOPMENT OF NON-DESTRUCTIVE CONDITION MONITORING TECHNIQUES FOR LOW-VOLTAGE CABLES

F. Guérout<sup>1</sup>, L. Cissé<sup>1</sup>, R. Boor<sup>1</sup>, and A. Blouin<sup>2</sup>

## ABSTRACT

Nuclear power plants contain more than one thousand kilometres of electrical cables. A large majority of these cables are dedicated to Instrumentation and Control (I&C) functions. I&C cables are key components of a nuclear power station because they link measuring and control equipment to the instrumentation used to monitor and control the plant.

Research data and operational experience show that nuclear power plant cable materials gradually become brittle and may crack, thereby resulting in loss of dielectric strength and increased leakage current. The main stressors causing age-related degradation are elevated temperatures and ionising radiation. Most cables installed at the CANDU<sup>®</sup> stations were initially qualified for a 30-40 year service life. As station personnel now face the prospect of plant life extension, the focus is on assessing the remaining life of the cables (including Design Basis Event (DBE) survivability) beyond the 30-40 year period.

The number of techniques available for on-site monitoring is limited because of the strong requirement from station personnel to use non-destructive and non-intrusive techniques. As a result, a CANDU Owners Group (COG) R&D project was initiated to develop new non-destructive and non-invasive techniques for on-site condition monitoring and help the station users assess the remaining life of installed cables.

This paper summarizes the results obtained to date using three non-destructive techniques: the measurement of cable indentation and post-indentation parameters, the measurement of electrical dissipation factors at low frequencies, and the measurement of sound velocity using laser-ultrasound.

## BACKGROUND

A typical I&C cable consists of multi-conductor assemblies insulated with fire-retardant material with an overall shield and an outer jacket. In addition, the cables used in CANDU stations may contain tape wraps that enhance electrical, mechanical, or fire protection properties.

The typical modes of degradation due to cable aging are embrittlement leading to cracks, loss of dielectric strength, and increased leakage current. The main stressors causing age-related degradation are thermal aging resulting from elevated temperatures and

---

<sup>1</sup> Atomic energy of Canada Limited, Chalk River Laboratories

<sup>2</sup> National Research Council Canada, IMI Boucherville

<sup>®</sup> CANDU is a registered trademark of Atomic Energy of Canada Limited (AECL).

ionising radiation. Other degradation stressors of I&C cables include mechanical stresses, humidity, hydrocarbon fluids, and ozone.

Insulation and jacket materials used for I&C cables are polymers that contain additives and fillers to improve aging resistance, electrical, mechanical and fire retardant properties. The most widely used jacket and insulation materials in older CANDU plants are polyvinyl chloride (PVC). In the newer plants the materials are chlorosulphonated polyethylene (CSPE), also known as Hypalon for the jackets and cross-linked polyethylene/polyolefin (XLPE/XLPO), and ethylene-propylene based elastomers (EPR, EPDM) for the insulation.

The level of degradation of the insulation and jacket materials attributed to aging depends upon the polymer compound used (presence of adequate additives, etc.), the pre-service (storage) and service environmental conditions (temperature, radiation, mechanical stress, humidity), and the elapsed service life (time factor).

The main chemical aging mechanisms of polymers result from scission, cross-linking, and oxidation reactions at the molecular level. The scission of alkoxyl or peroxide radicals usually leads to the scission of one macromolecular chain into two new chains. Cross-linking refers to the formation of covalent links between adjacent macromolecules and the formation of a dense network of chains. Oxidation reactions, which start from the formation of free radicals (because of the initial break of a covalent link under the effect of temperature and/or radiation), can lead either to chain scission or cross-linking. The organic materials usually undergo physical changes such as hardening and loss of flexibility as a result of exposure to heat and radiation. Another type of physical aging mechanism due to thermal aging is the evaporation and possible migration of plasticizers in PVC materials.

The level of degradation of a material can be assessed by tracking the changes of material properties. Some standard techniques used include: visual and tactile inspections, tensile tests, indentation tests, differential scanning calorimetry, Fourier Transform Infrared Reflectance (FTIR) Spectroscopy, measurement of swelling ratio, mass loss, plasticizer content, or change in density.

In the context of accelerated laboratory aging programs, the work consists first of selecting the most relevant and most sensitive aging characterization parameters for each material. The aging of polymers over the lifetime of the reactor/cables can be simulated in an accelerated manner. Degradation that occurs over years of operation can be duplicated in a few months of accelerated aging. Accelerated thermal aging of samples is carried out at carefully chosen sets of temperatures, durations to cover a wide range of levels of degradation to ensure that the accelerated conditions are still representative of aging taking place in nuclear power plants. The results are then used to derive Arrhenius law parameters that relate time, temperature, and degradation, or to derive other predictive aging models. Accelerated irradiation aging must consider dose rate as well as total dose. The models can be used to predict the design life of a cable material and the remaining life of a cable in service.

One of the most commonly used laboratory techniques to assess degradation is tensile testing, which consists of comparing the percentages of elongation at break (EAB) or the tensile strength for unaged and aged samples. EAB is a proven degradation indicator and

an accepted parameter for the estimation of the residual lifetime of a cable. End-of-life criteria based on this parameter are well established. An ultimate EAB of 50% is usually used as an end point criterion [1]. The main disadvantage is the large sample size required and the destructive aspect of the technique.

Most cables installed at the stations were initially qualified for a 30-40 year service life. As station personnel now face the prospect of plant life extension, the focus is on assessing the remaining life of the cable (including Design Basis Event (DBE) survivability) beyond the 30-40 year period.

The number of techniques available for on-site monitoring is limited because of the strong requirement from station personnel to use non-destructive and non-intrusive techniques. Another difficulty is that some of the instruments typically used in the laboratory environment are not easily portable to site.

Over the past few years, various panels of international experts were formed to review existing data and the state of advancement of current condition monitoring techniques [2, 3]. These panels provided guidelines and recommendations with respect to the orientation of Research and Development (R&D) programs to address cable aging issues. The recommendations for future research and development efforts to address this issue were as follows [3]:

- Continue the development of new, effective, in-situ condition monitoring techniques for installed wire systems that can be used to determine the current condition of a wire system and predict its useful life. In this regard, advanced electrical, optical, ultrasonic and aerospace technologies should be evaluated and developed for nuclear plant applications.
- Correlate mechanical wire system properties to electrical properties to better understand the significance of reaching the limits of mechanical properties for aged insulating materials.

The work performed at AECL under COG funding is largely based on feedback from station personnel and on some of the key recommendations and guidelines from international panels of experts. The scope of work was defined according to three main drivers:

1. Develop new non-destructive techniques for the assessment and monitoring of cable condition.
2. Develop tools to relate the non-destructive testing data to the electrical functionality of the cables.
3. Help station users assess the remaining life of installed cables.

## **INTRODUCTION**

The development work focused on three non-destructive techniques that could eventually be used in-situ at the nuclear stations using portable versions of the tools.

The first technique consists of indenting the cable insulation or cable jacket material to generate indentation and post-indentation parameters that characterize the visco-elastic properties of the material tested. The novelty of the technique developed at AECL

consists of measuring the time taken by the polymeric material to recover a set portion of the initial deformation and use this duration as the material degradation indicator.

The second technique is based on the measurement of insulation electrical dissipation factors (or tan delta), which is the ratio of loss current to stored current in the insulating material. When used on multi-pair conductor cables, this technique presents the advantage of providing a global indication of the cable condition. The novelty of the approach taken at AECL consists of using a broadband frequency tan delta analyser to measure electrical dissipation factors at various frequencies, find the frequency ranges showing increased sensitivity to cable degradation, and develop specific electrodes and techniques for practical on-site measurement.

The third technique consists of measuring the ultrasound velocity in the insulating materials. Conventional ultrasonic probes can be used to generate an ultrasonic wave in the cable jacket or cable insulation, detect it at a known distance from the generation point, and measure the ultrasound velocity in the material. However, the low-frequency probes required to minimize the attenuation of the signal are usually bulky and not very practical to use on small diameter cables. Moreover the sensitivity to cable degradation from thermal aging was not very high when using conventional ultrasound probes [4]. The novelty of the technique developed at NRC in collaboration with AECL consists of using ultrasounds generated and detected by lasers.

The initial focus of the R&D program was on PVC-jacketed and PVC-insulated cables. Using the three new techniques described above, results were compared for unaged reference samples, and for samples thermally aged and irradiated in the laboratory. The main objective was to select the test parameters and configurations that are most sensitive to cable degradation.

A large effort was also dedicated to the development of portable tools and to the modification of the measurement techniques for safe and practical use at the nuclear sites.

The results of the testing and tool development programs for the indentation, the electrical, and the ultrasound technique are detailed in the following sections of this paper.

## **MEASUREMENT OF INDENTATION AND POST INDENTATION PARAMETERS**

The indentation technique is a quantitative non-destructive cable condition monitoring technique that consists of driving a probe tip onto the surface of the cable jacket or cable insulation material [2]. The advantages of the technique are as follows:

- portable instruments can be developed,
- the measurement is quick, and
- data is easy to analyse.

During the indentation phase, the force and the displacement are measured to derive a stiffness parameter also called the “indenter modulus”. This parameter shows some correlation with cable degradation for most cable materials used in nuclear power plants but the sensitivity of the technique can be limited. In particular, two notable exceptions

are XLPE and irradiated PVC for which the indenter modulus values tend to stay constant or only change for a severely degraded material.

A sophisticated laboratory indenter called the Elasto-Dynamic Spot Tester (EDST) was first developed at AECL in the early nineties. Initially, the EDST was used to derive the elastomer spot stiffness during indentation and also to study various post-indentation viscoelastic properties, such as the percentage of force relaxed after a given time and the time to recover a given percentage of the initial deformation. A photograph of the EDST used for cable aging assessment at the CRL site is shown in Figure 1 below.



**Figure 1 EDST Test Stand Used to Assess Damaged Cables at CRL**

### **Development of a Portable Polymer Tester (PPT)**

The development of a portable version of the EDST, called the Portable Polymer Tester was started at AECL in 2006.

The identified main design requirements for the PPT were as follows:

- Design a compact tool using state of the art technology for the drive, control, feedback, and force/displacement measurement systems.
- Duplicate features/test characteristics of the existing EDST while adding the option of using the tool in any orientation.
- Integrate the option of using the indentation probe in oscillation mode to access new parameters such as the dynamic modulus or the mechanical dissipation factor.
- Take into account the possible tool exposure to contaminated, above ambient temperature environment when used at a nuclear site.

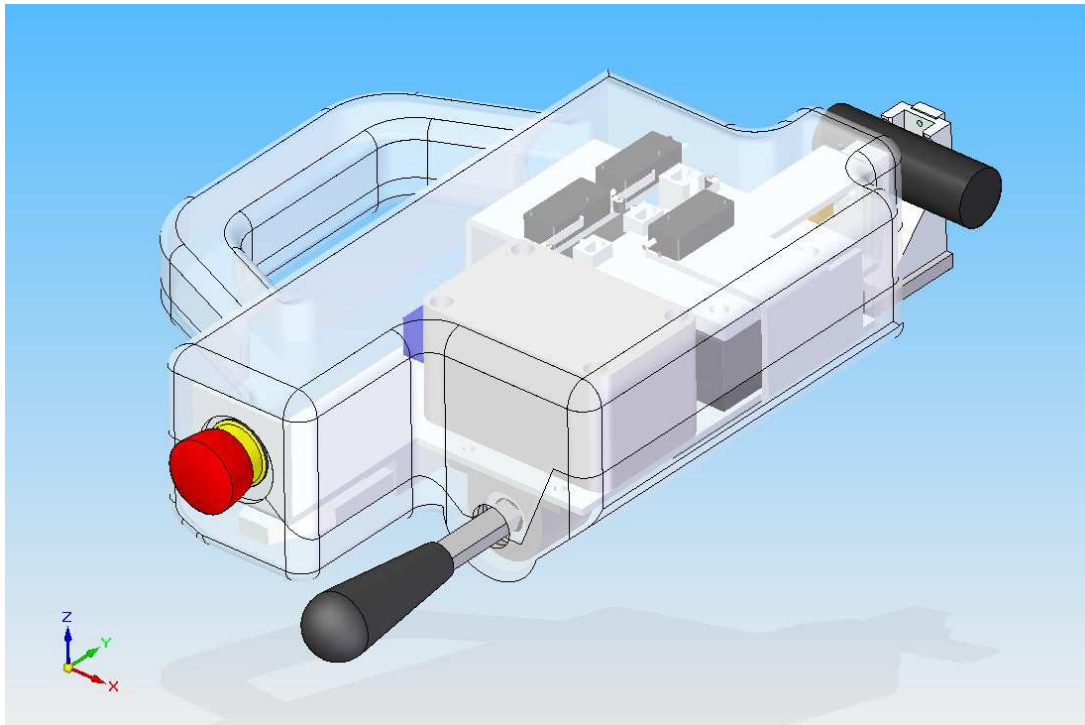
The drive system chosen integrates a ceramic servo motor into a stage. The stage configuration utilizes a linear slide with crossed roller bearings and a linear optical encoder. The stage is provided completely assembled. The ceramic servo motor used is capable of high resolution and high dynamic performance.

The force on the probe tip is measured using a miniature loadcell mounted to the front of the slide and a load cell signal conditioner. The linear encoder built in the stage provides the probe position measurement.

A 3D model of the prototype tool is shown in Figure 2.

The test sequence and data acquisition are controlled using a computer with Windows XP operating system. The Windows programming environment is LabView®<sup>3</sup> based. The Portable Polymer Tester offers the option of programming the indenter probe profile and controlling the probe position to derive post-indentation parameters. These parameters are similar to those accessed using the EDST. They include the force relaxation (once the material has been indented), and the time to recover a set percentage of initial deformation (once the indenter is quickly retracted following the relaxation phase). A typical PPT sequence is shown in Figure 3.

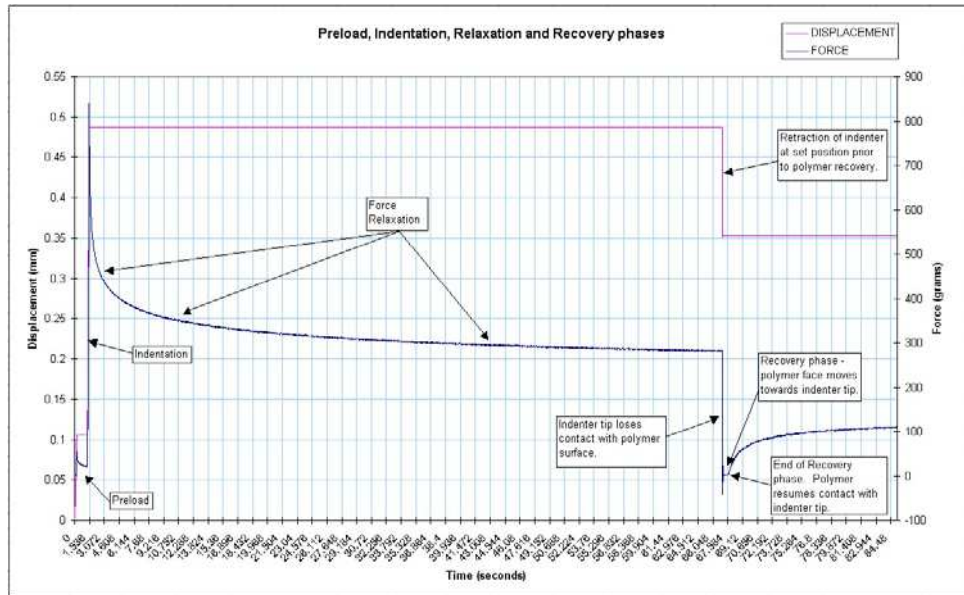
The results obtained to date using the PPT show good repeatability and are in line with the previous EDST results (non-portable version). Several field trials at the nuclear stations are scheduled in 2009 to further validate the performance of this portable tool.



**Figure 2 Tri-dimensional Representation of the Portable Polymer Tester (Prototype)**

---

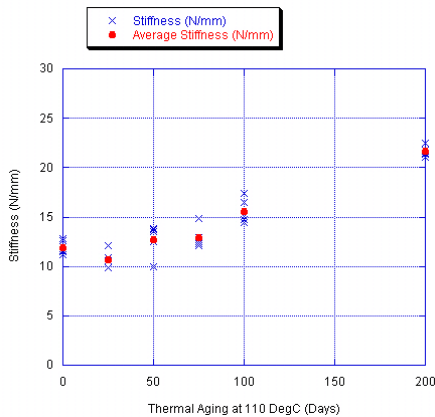
<sup>3</sup> LabView is a Registered Trade Mark of National Instruments.



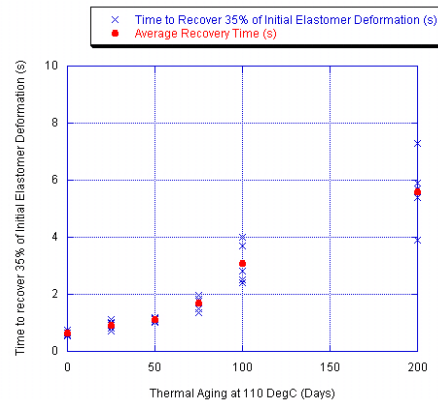
**Figure 3 Typical Test Sequence for the Portable Polymer Tester**

### PVC Cable Jacket Thermally Aged Only

A series of PVC cable jacket samples was thermally aged at 110°C in a ventilated oven for durations of up to 200 days. The stiffness results are shown in Figure 4. There is a gradual change in stiffness as a function of the number of thermal aging days, from 11.9 N/mm for the unaged samples to 21.7 N/mm for samples thermally aged during 200 days at 110°C. The time to recover 35% of the initial deformation is shown in Figure 5 as a function of days of aging at 110°C. It can be seen that the recovery time is very sensitive to the effect of increased thermal aging duration, with a change of about +75% after 50 days, +167% after 75 days, +392% after 100 days, and +788% after 200 days.



**Figure 4 Stiffness for a Thermally Aged PVC Cable Jacket**

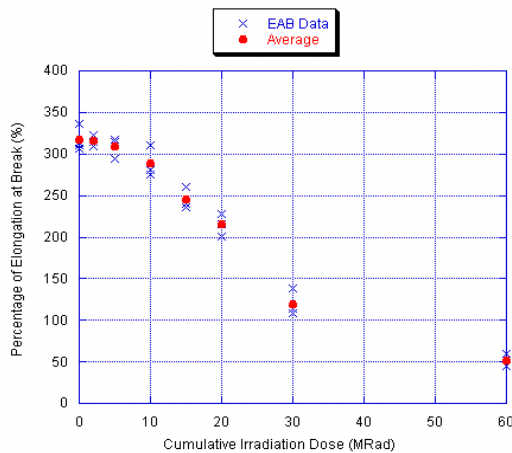


**Figure 5 Recovery Time for a Thermally Aged PVC Cable Jacket**

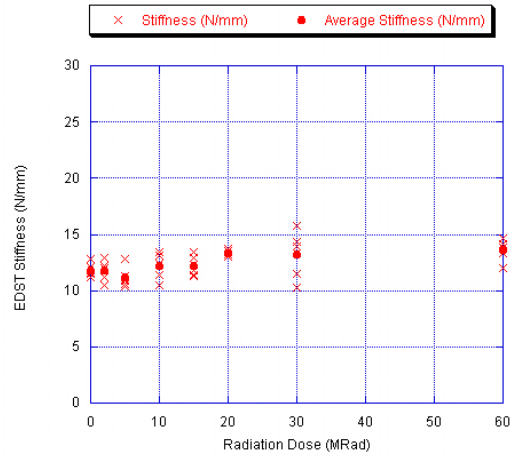
## PVC Cable Jacket Irradiated Only

A series of PVC cable jacket samples were irradiated in a gamma cell at doses ranging from 2 to 60 MRad. The reference elongation-at-break data for these irradiated PVC cable is shown as a function of irradiation dose in Figure 6. The graph shows that at 60 MRad the elongation-at-break is down to 50%, a level of degradation that corresponds to the commonly accepted end-of-life point for a cable [2].

The stiffness results for irradiated PVC cable jacket samples are shown in Figure 7. The stiffness parameter is not sensitive to the degradation resulting from PVC irradiation. This confirms what was found for earlier studies reported in the literature [2].

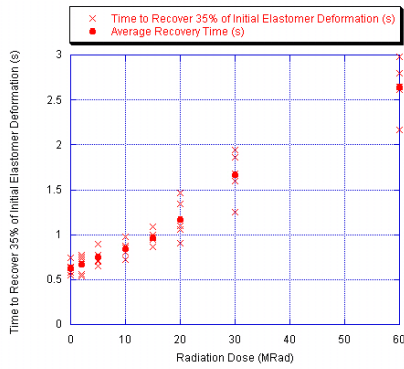


**Figure 6 EAB Results for the Irradiated Cable Jacket Samples**

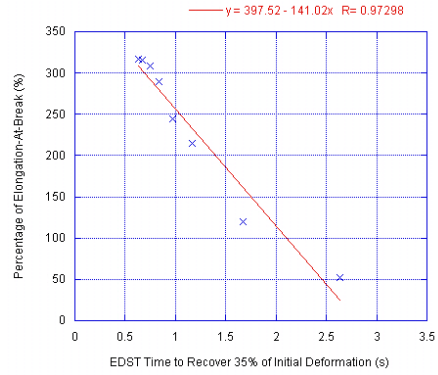


**Figure 7 Stiffness Results for the Irradiated Cable Jacket Samples**

The recovery of deformation data for the same irradiated samples is shown in Figure 8. The time to recover one third of the initial deformation increases almost linearly as a function of irradiation dose. From the unaged condition, there is an increase of the average recovery time of 33% at 10 MRad, 86% at 20 MRad, 165% at 30 MRad, and 320% at 60 MRad. Therefore, this new approach using the recovery time provides a means of assessing, for the first time, the degradation of irradiated PVC while using an indentation method. Moreover, the deformation recovery time correlates very well with the EAB values measured for the various irradiation levels, with both parameters being extremely sensitive to the material degradation. The good correlation between the elongation-at-break and the time to recover one third of the initial deformation is shown in Figure 9.



**Figure 8 Recovery of Deformation for Irradiated Cable Jacket Samples**

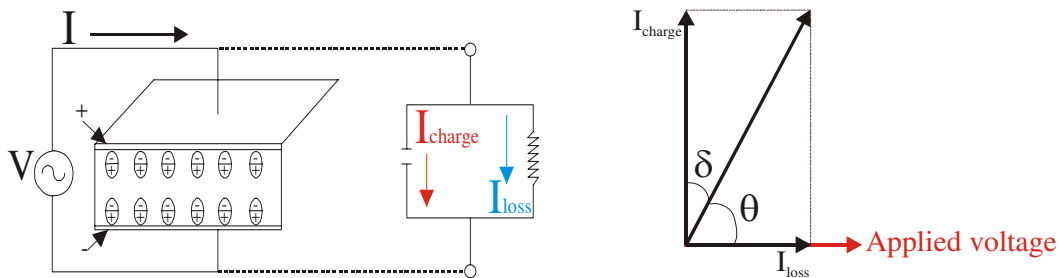


**Figure 9 Correlation of EAB and EDST Recovery Results**

### MEASUREMENT OF ELECTRICAL DISSIPATION FACTORS OVER A BROAD FREQUENCY RANGE

Dissipation factors are measured to characterize the dielectric properties of a material. A key feature of a dielectric material lies with its ability to store electrical energy when an external electrical field is applied. For insulating materials used in cables, the objective is to prevent the storage of electrical energy and therefore keep the dissipation factors as low as possible. However, as the insulating material ages, the insulation properties decrease and dissipation factors tend to increase. Therefore, the measurement of dissipation factors in cables could prove useful to monitor their condition.

The insulation current resulting from the application of an AC sinusoidal voltage ( $u(t) = V\sin(\omega t)$ ) consists of two components: the charge current and the loss current. Electrically, a degraded insulation can be represented by a conductance (G) in parallel with a capacitance (C). The current flowing through the capacitor is the charge current ( $I_{\text{charge}}$ ) and the current flowing through the conductance is the loss current ( $I_{\text{loss}}$ ), as shown in Figure 10. The loss current is in phase with the applied voltage while the charge current is out of phase with the applied voltage. For an ideal insulating material, the current flowing through is capacitive. However, a new insulation material presents some losses through the conductance and this effect increases as a result of aging.

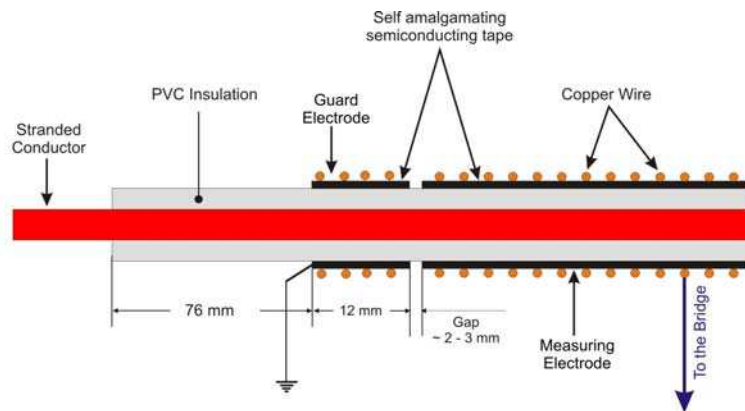


**Figure 10 Definition of the Electrical Dissipation Factor ( $\tan\delta$ )**

The ratio of lost energy to stored energy in the insulating material is called the loss tangent or dissipation factor. It is defined as follows:  $\tan\delta = I_{\text{loss}}/I_{\text{charge}}$ . In Figure 10,  $I_{\text{charge}} = j\omega CV$ , and  $I_{\text{loss}} = VG$ , where  $C$  is the capacitance and  $G$  the conductance of the tested material.  $V$  and  $\omega$  are related respectively to the applied voltage and the frequency. As the insulating material ages,  $I_{\text{loss}}$ , and therefore  $\tan\delta$ , tend to increase. However, at the typical frequency of 60 Hz, the technique is usually not very sensitive to polymer degradation. The novelty of the AECL approach consists of using a broadband frequency tan delta analyser to measure electrical dissipation factors at various frequencies, and find the frequency ranges showing increased sensitivity to cable degradation. The frequencies can range from  $10^{-3}$  to  $10^3$  Hz. The signal is usually amplified internally and then applied to the cable sample. The ac voltage chosen for this test program was 200V, peak to peak.

### Reference Semi-Conductive Tape Measurement Technique

For this measurement technique, the cable insulation is wrapped with self-amalgamating conductive tape and tinned copper wire to form a measuring electrode. To avoid stray currents during dissipation factor measurements, a guard electrode is added near the measuring electrode. A typical cable configuration for this measurement technique is shown in Figure 11.



**Figure 11 Configuration For Measurement of Electrical Dissipation Factors Using Self-Amalgamating Conductive Tape**

This technique is very reliable and very sensitive to variations of electrical dissipation factors resulting from thermal aging and/or irradiation of the cables. Electrical dissipation factors were measured using five different types of unaged PVC cables (different manufacturers, temperature ratings, fire-resistance ratings, geometries) in order to assess the “universality” of this technique. The single conductors of five types of cable tested using the “conductive tape” technique were as follows:

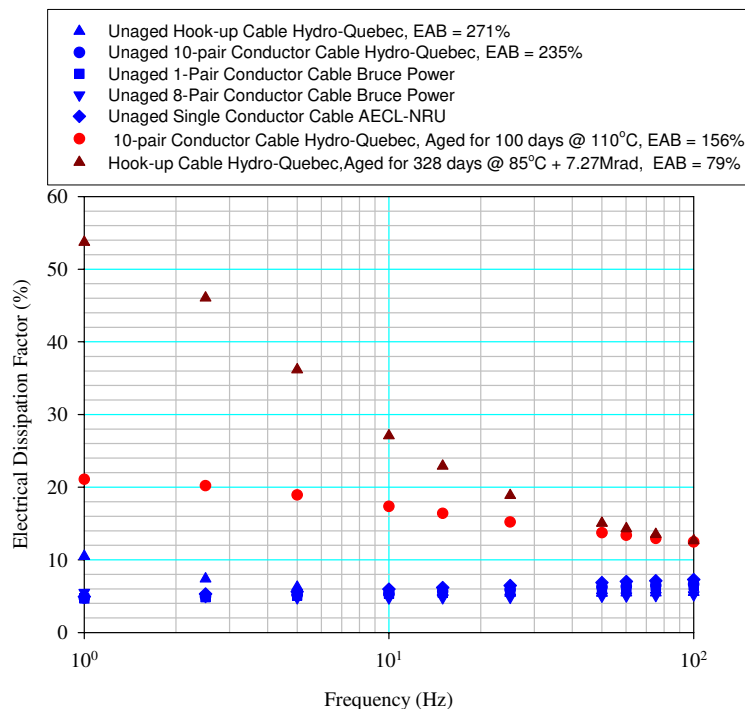
- A hook-up single conductor cable provided by Hydro Quebec.
- A 10-pair conductor cable provided by Hydro Quebec.

- A 1-pair conductor cable provided by Bruce Power.
- An 8-pair conductor cable provided by Bruce Power.
- A single conductor cable obtained from the NRU reactor in Chalk River.

The electrical dissipation factor results obtained for these five unaged cables at frequencies ranging from 1 to 100 Hz are shown in blue in Figure 12. The reference EAB measured for two of the unaged cables was 271 and 235%, respectively. The electrical dissipation factor values are very repeatable from one type of PVC insulation to the other. For example, at 10 Hz, the data obtained for the five cable samples was always between 4.5 and 6 %.

One of the 10-pair conductor cable provided by Hydro-Quebec was thermally aged at 110°C (EAB of 156%). The broadband electrical dissipation factor measurements on this sample are shown in red in Figure 12. The results show that the technique is very sensitive to cable degradation especially at low frequencies. For this thermally aged cable, the electrical dissipation factor measured at 5 Hz, increased by a factor of three from the unaged reference data.

One of the hook-up single conductor cable was thermally aged for 328 days at 85°C and irradiated to a dose of up to 7.27 Mrad (EAB down to 79%). The broadband electrical dissipation factor measurements on this sample are shown in brown in Figure 12. For this thermally aged and irradiated cable, the electrical dissipation factor measured at 5 Hz, increased by a factor of six from the unaged reference data.



**Figure 12 Comparison of Electrical Dissipation Factor Results Obtained for a Variety of PVC Cables Using the Semi-Conductive Tape Technique**

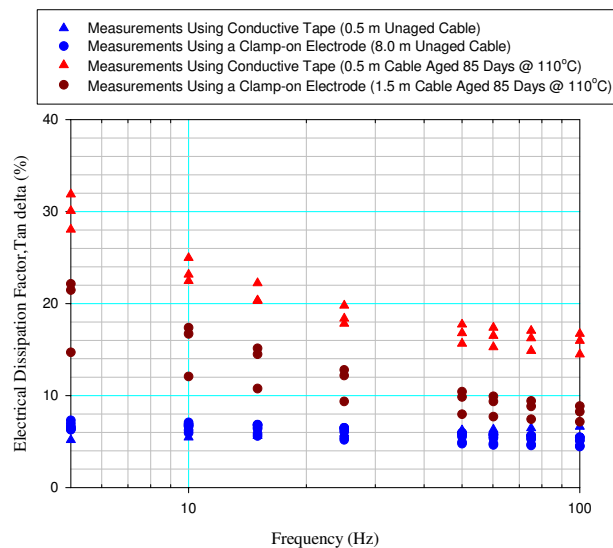
Although the semi-conductive tape technique can be used both on jacket and insulation, it would be very intrusive and time consuming for nuclear site applications. It is, therefore, mainly used in the laboratory to provide benchmark reference results and assess the reliability of other less intrusive dissipation factor measurement techniques.

### Clamp-Electrode Measurement Technique

For this technique, a metallic clamp replaces the semi-conductive amalgamating tape. The experimental set-up is therefore simplified and more practical to use in the field. However, with the clamp electrode technique, de-energization and disconnection of the cable is still required.

The first electrode called the input voltage electrode carries the voltage and is directly connected to the cable conductor. A portion of the cable sample is inserted into a clamp electrode (the second electrode) where the current through the cable insulation is measured. A third electrode is connected to the ground and guard wire (not shown). This technique can be used directly on the insulation of non-jacketed single conductor cables such as, for example, hook-up cables.

Although the clamp electrode measurement technique is more rudimentary than the reference semi-conductive tape technique, the results obtained for an unaged cable were in good agreement and were consistent when taken over the entire length of the cable. For thermally aged cables the sensitivity to cable degradation decreased slightly when using the clamp electrode from what could be detected when using the semi-conductive tape. However, the degradation was still revealed. For example, as shown in Figure 13, when applied to a PVC cable thermally aged for 85 days at 110°C, the average semi-conductive tape tan delta measured at 5 Hz was 30%. The corresponding clamp electrode average value was 20%. The electrical dissipation factors measured on the unaged sample using both techniques were 5 and 6.5%, respectively.

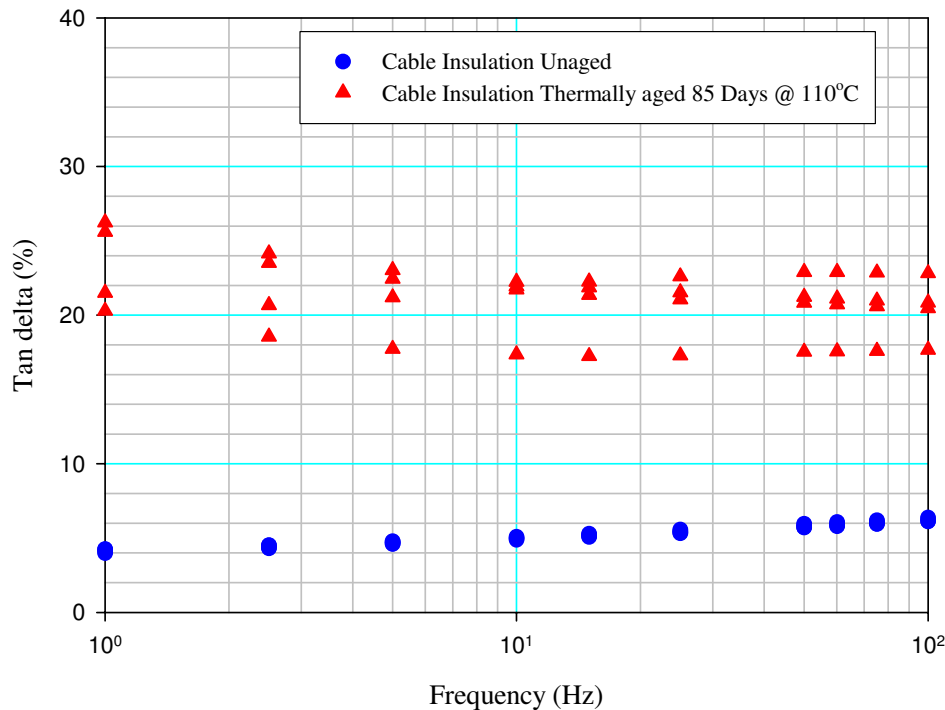


**Figure 13 Comparison of Electrical Dissipation Factors Measured Using the Semi-Conductive Tape and the Clamp Electrode Techniques**

## Cable-End Measurement Technique

This technique was developed for jacketed multi-pair conductor instrumentation and control cables. For these cables, the conductors within one pair are intertwined and, as a result, the insulation of both conductors is in contact at multiple points along the length of the cable. The input voltage electrode is directly connected to one of the conductors. The measuring electrode is connected to the second conductor within that pair. A third electrode is connected to a ground wire within the cable. The ground wire is used as a guard electrode. The electrical dissipation factor is measured using the insulation contact points within one given pair of conductors. Therefore, it provides a global assessment of the insulation degradation over the entire length of the cable (via the contact points), and there is no cable length limitation to the application of this technique.

The electrical dissipation factors measured using this technique are similar to what was previously obtained when using the semi-conductive tape laboratory technique. For a PVC cable thermally aged during 85 days at 110°C, the semi-conductive tape tan delta measured at 10 Hz ranged from 22 to 25% (see Figure 13). The electrical dissipation factor measured from cable end ranged from 18 to 22%, as shown in Figure 14. The electrical dissipation factors measured on the unaged sample using both techniques were around 5% (see Figures 13 and 14).



**Figure 14 Electrical Dissipation Factors Measured from the Cable Ends of a Multi-Pair Conductor Cable**

## MEASUREMENT OF SONIC VELOCITY USING LASER ULTRASOUND

Laser-ultrasonics is a technique based on the use of lasers to generate and detect ultrasound. The absorption of energy from a single laser pulse by the material surface creates a local heated zone at the surface, which generates ultrasound within a broad frequency band. The ultrasound is generated within the specimen by thermal expansion of this heated zone. This process generates several types of acoustic waves in solids: longitudinal waves (L-waves), shear waves (S-waves) and surface acoustic waves (SAW, Rayleigh waves or P-waves) [5, 6].

The acoustic waves are reflected at the interface between two media of different acoustic impedance and consequently small surface displacements of a few nanometres are induced. These surface displacements are detected with a sensitive detection system composed of a second laser and an interferometric system [7]. Velocity measurements of the bulk material can be performed using longitudinal waves, shear waves, and surface waves.

The time for the wave to travel from the generation to the detection laser spots can be measured. The measured velocity corresponds to the ultrasound propagating distance between the two probes divided by the travel time. From a physics point of view, the speed at which sound propagates through a solid medium is related to both density and modulus as:

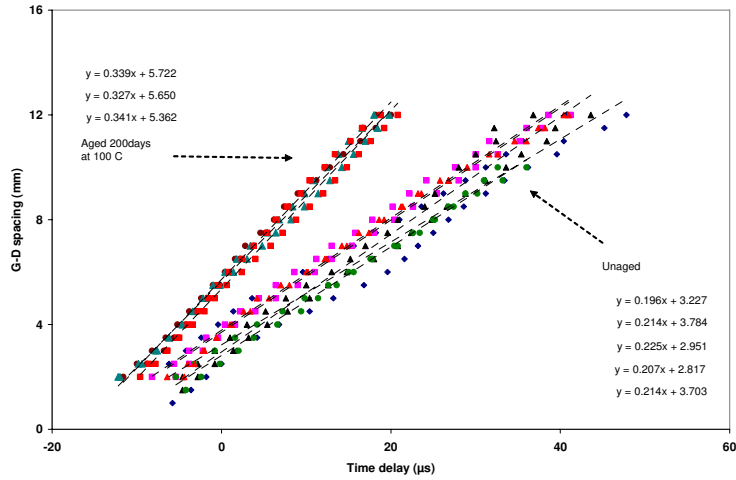
$$C^2 = \frac{E}{\rho} \quad (1)$$

where  $C$  is the sonic velocity,  $E$  is the elastic modulus, and  $\rho$  is the material density. Since the velocity is related to the modulus and density of the material (two parameters that are usually affected by aging), the measured sonic velocity can potentially be a good indicator of material degradation.

The preliminary investigation of the potential of using laser ultrasound to assess the cable condition revealed that, for a low-frequency mode, the change in sound velocity could be correlated to the change in elongation-at-break for the thermally aged cables. Following this discovery, the test setup was adapted to optimise the measurements performed using this low frequency mode: the interferometer and the detection laser were selected for the proper detection of this type of ultrasonic mode. A cylindrical lens was also used to focus the generation laser on a line (1 mm wide) instead of a spot, resulting in increased ultrasonic wave amplitude along the cable axis. The measurement strategy consisted of scanning the distance between the generation and detection (G-D) spots. In each scan, the G-D separation was varied from -15 mm to 15 mm with a step size of 0.5 mm. The signal was averaged 10 or 30 times for each G-D separation to improve the signal-to-noise ratio. Once the optimised set-up was reached, the low frequency mode could be generated in a reproducible manner with a very good signal-to-noise ratio. The low-frequency mode is thought to be a flexural mode of the cable. This mode was consistently generated in the thermo elastic regime, hence leaving virtually no mark on the jacket. Therefore, the non-contact technique is non-intrusive and non-destructive.

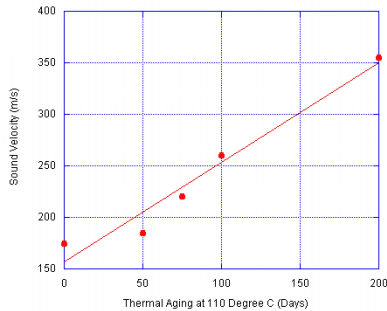
The low frequency flexural mode for the unaged cable was below the velocity of sound in air. Typical signals for different G-D separations were obtained on the unaged cable and on a cable aged 200 days at 110<sup>0</sup>C. Measurements were taken at several locations along

the cable axis and circumference. The results are shown in Figure 15. A large difference in sound velocity can be observed as a result of thermal aging. The measurements are repeatable and are all within 5% of the average value.

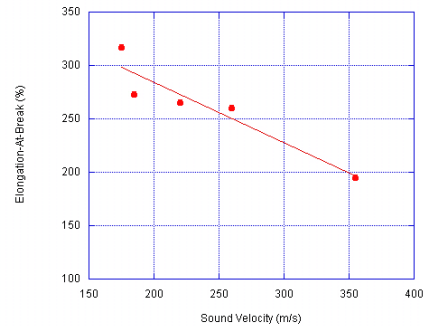


**Figure 15 Sound Velocity Measured at Different Cable Locations for an Unaged and a Thermally Aged Cable**

Measurements were then taken for a variety of thermally aged cables (aged 50, 75, 100, and 200 days at 110°C). The results are shown in Figure 16. The sound velocity increased linearly with aging from 175 m/s for the unaged cable to 355 m/s for the cable aged 200 days at 110°C. The sound velocity measured for the low frequency is therefore highly sensitive to cable degradation. Moreover, as shown in Figure 17, there is a strong correlation between the reference EAB results and the sound velocity results.



**Figure 16 Sound Velocity for Cable Samples Thermally Aged at 110°C**



**Figure 17 Correlation of Elongation-At-Break and Sound Velocity for Cable Samples Thermally Aged at 110°C**

## **CONCLUSION**

An R&D initiative was undertaken at AECL to develop a set of new non-destructive techniques and portable tools for on-site cable assessment. Three main cable condition monitoring techniques were investigated: the indentation technique, the measurement of electrical dissipation factors, and the laser ultrasonic technique.

The novelty of the indentation technique developed at AECL consisted of measuring the time taken by the polymeric material to recover a set portion of the initial deformation and use this duration as the material degradation indicator. The results showed that the recovery time is much more sensitive to cable degradation than the stiffness (indenter modulus) measured during the indentation phase, and this high sensitivity is achieved for both thermally aged and irradiated cable samples.

Electrical dissipation factors using the reference semi-conductive tape technique were measured for a variety of PVC cables (five dissimilar unaged cables and two different thermally aged cables). The measurements were taken over a broad range of input frequencies. The results for the unaged cables showed that the electrical dissipation factors were independent of compound formulation. For the thermally aged or irradiated cables the most interesting trend was the increased sensitivity to degradation obtained when measuring electrical dissipation factors at low frequencies.

Other measurement techniques that are simpler and more practical to use than the semi-conductive tape technique were developed and investigated. A clamp electrode was successfully used to assess the degradation of hook up cables. A technique consisting of measuring the electrical dissipation factor at the cable ends was also developed for the multi-pair conductor cables. Additional development work will be performed to investigate the potential measurement of electrical dissipation factors in jacket materials.

The laser ultrasonic work revealed that the sound velocity of the low-frequency mode measured using a generation and a detection laser for a low frequency mode was more sensitive to cable degradation than when using classical ultrasonic probes. The sound velocity was also successfully correlated to the reference elongation-at-break results.

## **ACKNOWLEDGMENTS**

The authors would like to thank the COG CMC technical committee members and the station representatives for supporting and funding this R&D initiative.

## REFERENCES

- [1] International Atomic Energy Agency, 2000, "Assessment and Management of Ageing of Major Nuclear Power Plant Components Important to Safety: In-Containment Instrumentation and Control Cables", Volume 1, IAEA-TECDOC-1188, December.
- [2] International Atomic Energy Agency, 2000, "Assessment and Management of Ageing of Major Nuclear Power Plant Components Important to Safety: In-Containment Instrumentation and Control Cables", Volume 1, IAEA-TECDOC-1188, December.
- [3] Nuclear Energy Agency, Committee on the Safety of Nuclear Installations, 2004, "Research Efforts Related to Wire Systems Aging in NEA Member Countries", Report NEA/CSNI/R, (2004)12, August 11.
- [4] Nishida, Y., 2001, "Non-Destructive Diagnosis Technique for Aging of Cables Used at Nuclear Power Plants, Nuclear Engineering and Design 207, 317.
- [5] Hutchins, D.A., 1986, "Mechanisms of Pulsed Photoacoustic Generation", Can. J. Phys., Vol. 64, pp. 1247-1264.
- [6] Radziszewski, L., 1994, "On Generating Ultrasounds by Laser in Polymers", Archives of Acoustics, Vol. 19, 3, pp. 381-393.
- [7] Monchalín, J.P., 1985, "Optical Detection of Ultrasound at a Distance Using a Confocal Fabry-Perot Interferometer", Appl. Phys. Lett., Vol. 47 (11), pp. 14-16.