

NRC Publications Archive Archives des publications du CNRC

Diplex gating unit Hunt, F. R.

For the publisher's version, please access the DOI link below./ Pour consulter la version de l'éditeur, utilisez le lien DOI ci-dessous.

Publisher's version / Version de l'éditeur:

<https://doi.org/10.4224/21274164>

Report (National Research Council Canada. Radio and Electrical Engineering Division : ERB); no. ERB-622, 1962-12

NRC Publications Archive Record / Notice des Archives des publications du CNRC :

<https://nrc-publications.canada.ca/eng/view/object/?id=1426f0ec-7547-43d9-bb71-93cf4ec44b57>

<https://publications-cnrc.canada.ca/fra/voir/objet/?id=1426f0ec-7547-43d9-bb71-93cf4ec44b57>

Access and use of this website and the material on it are subject to the Terms and Conditions set forth at

<https://nrc-publications.canada.ca/eng/copyright>

READ THESE TERMS AND CONDITIONS CAREFULLY BEFORE USING THIS WEBSITE.

L'accès à ce site Web et l'utilisation de son contenu sont assujettis aux conditions présentées dans le site

<https://publications-cnrc.canada.ca/fra/droits>

LISEZ CES CONDITIONS ATTENTIVEMENT AVANT D'UTILISER CE SITE WEB.

Questions? Contact the NRC Publications Archive team at

PublicationsArchive-ArchivesPublications@nrc-cnrc.gc.ca. If you wish to email the authors directly, please see the first page of the publication for their contact information.

Vous avez des questions? Nous pouvons vous aider. Pour communiquer directement avec un auteur, consultez la première page de la revue dans laquelle son article a été publié afin de trouver ses coordonnées. Si vous n'arrivez pas à les repérer, communiquez avec nous à PublicationsArchive-ArchivesPublications@nrc-cnrc.gc.ca.

MAIN Ser
QC1
N21
ERB-622
c.2

ERB-622

Confidential **SECRET**

COPY NO. *21*

NATIONAL RESEARCH COUNCIL OF CANADA
RADIO AND ELECTRICAL ENGINEERING DIVISION

DIPLEX GATING UNIT

F. R. HUNT

Declassified to:
ORIGINAL SIGNED BY
ORIGINAL SIGNÉ PAR
Authority: *S. A. MAYMAN*
Date: **NOV 26 1992**

OTTAWA

DECEMBER 1962 *NRC # 35656*

ABSTRACT

The RCAF has programmed a new antenna for their dual-channel radar, the AN/FPS-508. Fitted to this antenna is a Vari-Polarizer which permits simultaneous operation of both channels of the radar, i.e., operation in a diplex mode. At the request of the RCAF, the National Research Council developed the Diplex Gating Unit which automatically selects the outputs of the receivers in the channel affected least in a jammed environment. These outputs are then fed to the AN/FST-2 Data Transmission Equipment and the AJ Console. The construction and testing of the experimental and service test models are described in this report. A solution is given to the crosstalk problem that is likely to be encountered with the use of the Wide-Band Dicke Fix receivers when operating in the diplex mode. Minor modifications are recommended for use in a production model in order to increase reliability and ease of maintenance.

CONTENTS

	<u>Page</u>
History	1
Experimental Model	1
Service Test Model	3
Transmitter Frequencies	5
Recommendations	5
Acknowledgements	6
Reference	6

FIGURE

1. Block Diagram of Diplex Gating Unit

PLATES

- I. Experimental Model
- II. Service Test Model

DIPLEX GATING UNIT

- F. R. Hunt -

HISTORY

Late in 1961, the RCAF became aware of the development in the United States of a new antenna suitable for the AN/FPS-508 radar. This antenna, the OA3424/FPS-73, has significantly lower side lobes than the present antenna. It is also fitted with a Vari-Polarizer which allows both channels of the dual-channel radar to operate simultaneously with orthogonal polarization of the two outputs (i.e., it permits operation in a diplex mode). Linear or circular polarization of the two outputs is also provided.

In October 1961, the Directorate of Electronic Warfare at RCAF Headquarters posed to NRC the problem of making the best use in a jammed environment of an AN/FPS-508 fitted with this antenna. The solution proposed by NRC and accepted by the RCAF was the Diplex Gating Unit. Basically the unit compares the outputs of a jamming power measuring receiver fitted to each channel. After the unit has made a decision, it then switches the output of the desired ECCM receiver in the least jammed channel to the AN/FST-2 data transmission equipment. NRC built an experimental model (Plate I) of the Diplex Gating Unit and this was tested at RCAF Station Foymount in January 1962.

As a result of the success of the preliminary test, the RCAF introduced this item to the Joint USAF/RCAF ECCM Evaluation Group. At the same time, the Napkin Committee was approached and agreed to have a Service Test Model built by Canadian Arsenals Limited. This model (Plate II) was completed by October 1962. A joint evaluation was made at a USAF site in this month. The unit performed satisfactorily and it is now ready for production, if required. The minor modifications recommended later in this report will further improve the performance and aid in maintenance.

EXPERIMENTAL MODEL

The experimental model built by NRC is shown in Plate I, and a block diagram of the unit is shown in Fig. 1.

The radar trigger (preferably a pre-trigger such as that used for SIF) is fed to the trigger amplifier V1A. This trips the monostable multivibrator V2 which provides a delay of approximately 10 μ sec. The undelayed output 'A', is used as a trigger pulse, for the trigger gates V13 and V23. The delayed output is used to trigger the monostable reset multivibrator V3. The delay time of V3 is variable and is adjusted to equal that of the most distant permanent echoes. Thus, if logarithmic receivers are used as the

power measuring device in place of the stepped-gain receiver [1], the strength of the permanent echoes (which could be quite different on the two polarizations) would play no part in the decision as to which channel is the most jammed. The output 'B' of the reset multivibrator trips the reset circuits which set the integrators to zero at the start of each radar pulse period and hold them at zero until the end of the permanent echo period.

The input from each power measuring receiver, either stepped-gain or logarithmic, is amplified and integrated. With the stepped-gain receiver, the amplitude of the input pulse remains constant, but its length in time is dependent on jamming strength. The length of time of integration is constant for the logarithmic receiver, but the amplitude varies with the jamming strength. In either case, after integration, the channel with the greatest jamming will produce the largest output. The outputs of the two integrators are connected to the two cross-connected trigger gate tubes V13 and V23. The gate tube connected to the largest integrated output will allow the trigger pulse 'A' to be passed to the corresponding input of the bistable multivibrator V14B and V24B. This multivibrator will then alter its mode if it happens to be in the opposite mode during the previous pulse period. Switching occurs at the start of each radar inter-pulse period.

The two outputs of the bistable multivibrator are used to set the gate amplifiers so that the proper ECCM receiver is connected to the output. Note that the ECCM receiver output is that of the least jammed channel, while the power receiver output is that of the most jammed channel. The reason for feeding the worst jammed channel to the Azimuth Time Recorder is to provide a better record for use by the operator of this passive detection equipment.

Also shown in Plate I is the remote control unit which provides over-ride control by the ECCM officer. This allows him to use either automatic selection of channels or manual selection of either channel. A fourth position allows addition of the outputs of the two ECCM receivers. The value of this circuit is unknown, but was included, as it involved very few additional circuit components. Signal lights on the remote unit, as well as on the main unit, indicate which ECCM receiver is in use. A meter was provided on the unit to facilitate equalizing the noise level inputs of the two ECCM receivers. Numerous oscilloscope test points were provided for ease in maintenance of the unit.

The testing of this unit at RCAF Station Foymount was preliminary only, as one of the new antennas was not available in Canada. The unit was, however, connected into both channels of the AN/FPS-508. Tests were carried out to determine the switching sensitivity of the unit. This was done by simulating jamming approximately 20 db above the thermal noise level in channel 1. A c-w signal from the L-band signal generator was then introduced into channel 2 and increased until switching action occurred. It was found that switching action took place 100 per cent of the time within

a 5 db range of the signal generator output. For example, on one test no switching occurred with a signal generator output of -54 dbm with channel 2 as the selected channel. Then as the input from the signal generator was increased, channel 1 was more and more the selected channel until with an input of -49 dbm, channel 1 was 100 per cent of the time the selected channel. The signal generator output was then decreased and at -54 dbm, channel 2 was again the selected channel 100 per cent of the time. Thus, one could say that for 100 per cent probability of switching, a 5 db difference in the two jamming signals was required. As a guess, for a 50 per cent probability of switching, a 2 db difference is required. For other than the 100 per cent probability measurements, more extensive equipment would have been required than was available at that time. It was felt that the sensitivity was adequate.

With the jamming in both channels approximately equal so that considerable switching occurred, the switched output of the two ECCM receivers was examined on the PPI. Switching transients less than 10 μ sec in duration were occurring just after the transmitter pulse. However, since the detection of targets within a mile of the radar is virtually impossible, these short switching transients are unlikely to bother the AN/FST-2 and can be ignored.

SERVICE TEST MODEL

The Service Test Model as built by Canadian Arsenals Limited is shown in Plate II. No basic circuit changes were made from the experimental model. The unit was expanded to handle more than one type of ECCM receiver and to integrate the diplexing operation with the Anti Jamming Console OA-5038. These changes are listed below:

- 1) The Diplex Gating Unit accepts the video outputs from four receivers (Normal Linear, Cascaded Dicke Fix, Logarithmic, and MTI) from each channel of the radar. The unit can select automatically the video outputs from the channel with least jamming. In addition, provision is made for remote manual selection at the AJ Console for the best type of receiver (Dicke Fix, Logarithmic, or Normal) in the least jammed channel to be fed to the AN/FST-2. The MTI receiver video output in the least jammed channel is fed to the AN/FST-2 by a parallel circuit. The override feature is still provided in this model for the ECCM officer to select either Automatic, Channel 1, Channel 2, or Add modes of operation.
- 2) A control is provided at the AJ Console which will allow the operator to balance the decision circuitry. Indicator lamps are also provided on the console to show which channel is in use. By adjusting the control and observing the results on the lamps, the operator is able to balance the decision circuitry to within about 3 db of perfect balance.

- 3) Video outputs to the AJ Console, independent of the output to the FST-2, are provided for monitoring purposes.
- 4) Provision is made for remote selection, by the Azimuth Time Recorder operator, of either channel or of the automatic mode of operation.
- 5) All circuits except the power supply are in the form of printed circuit cards to facilitate future production.
- 6) Because of the limitations on the power-handling capability of the microwave components, one transmitter fires 15 microseconds before the second transmitter. There is sufficient room behind the circuit boards to install the delays required in the video lines from one channel to bring the signals in the two channels into time coincidence.
- 7) Originally it was thought that part of the Threshold Control Unit could be mounted in the same rack. Later developments showed that this was unlikely. However, it was decided to leave the two spare drawers (the two middle ones) for use in future equipment developments.

The service test model was set up at the USAF base at Saratoga Springs where a model of the new antenna was installed. The narrow-band Dicke receivers at this site were used as the ECCM receiver. Stepped-Gain receivers were used to measure the jamming power.

Initially a General Electric Video Quantizer and electronic counters were used in the evaluation. The pulse generator used with the Quantizer produced a series of ten pulses at a range greater than the permanent echo pattern at this site. FM/N jamming was provided in one channel by an AN/ULT-501 fed through an antenna pattern simulator.

With no jamming present, the Gating Unit and Quantizer were set up to provide the same number of False Alarms on Automatic Channel 1, Channel 2, and Add positions of the video selector switch. Jamming was then fed into one channel and the number of false alarms counted for each position of the switch. The jamming level was increased but there was no increase in the number of false alarms. From the switching lights provided on the unit, it was obvious that the gating unit was switching satisfactorily. The unchanged false alarm rate in the jammed channel was due to the CFAR characteristics of the ECCM receiver being used. The output of the Diplex Gating Unit was connected to a PPI and no switching transients were observed.

In order better to demonstrate the Diplex Gating Unit, normal linear receivers were substituted for the ECCM receivers. The output of the unit was again viewed

on a PPI and its benefit illustrated when various positions of the video selector switch were used.

An aircraft fitted with an AN/ALT-501 jammer was then flown against the station. The difference in jamming levels between the two channels was provided by the orthogonal polarizations of the two channels. The unit performed satisfactorily, choosing the least jammed channel when in the automatic mode. No switching transients were noted on either the PPI or the little 'd' display of the AN/FST-2.

TRANSMITTER FREQUENCIES

The radar test site at South Truro was also capable of duplex operation. During earlier trials of the Wide-Band Dicke Fix receivers at the site, c-w jamming was experienced in a Dicke Fix receiver owing to crosstalk from the STALO (Stable Local Oscillator) of the other channel. This occurred when the frequency of the STALO of the second channel was within about 15 mc/s of the transmitter frequency of the first channel. This problem may be encountered in the operation of the radars fitted with the new antenna if sufficient isolation between the two channels is not provided by the Vari-Polarizer. Since Wide-Band Dicke Fix receivers were not available at Saratoga Springs, tests were not carried out at that time. However, to forestall any future difficulties when the antennas are installed in Canada, tests were carried out by the RCAF on the feasibility of using a common STALO for both channels. These trials were successful, and required only the substitution of new attenuators in the STALO chassis.

If common STALO operation is required, this will force a site to operate its two transmitters with a frequency separation of 60 mc/s. However, since any other radar site may operate on any other two L-band frequencies separated by 60 mc/s, this is not considered a great defect in frequency diversity. Thus, a five station net using duplex operation could cover the whole of the 1250-1350 mc/s L-band at 10 mc/s spacing. It should be noted, that for a given radar site to change frequency, only retuning of both transmitters is required. No change in waveguide structures is required, as is necessary in some duplex schemes.

RECOMMENDATIONS

The Service Test Model of the Duplex Gating Unit performed its automatic switching role satisfactorily and no switching transients were introduced that degraded the AN/FST-2 radar performance. Therefore, when the new antenna is received by the RCAF, the Vari-Polarizer, Duplex Gating Unit, and the other necessary modifications for duplex operation of the AN/FPS-508 should also be adopted. With the two transmitters operating, perhaps 60 mc/s apart in frequency, the jamming aircraft is forced to cover a broader portion of the L-band spectrum

at a substantial reduction in jamming power per unit frequency, or to carry additional equipments. The Vari-Polarizer with its orthogonal transmissions will force the aircraft to increase its over-all jamming power, or to carry two sets of antennas to achieve the same result.

The following recommendations are for minor improvements to the Service Test Model to improve its reliability and ease of maintenance:

- 1) The meter used to balance the noise outputs of the video amplifiers in the Diplex Gating Unit requires improvement. This would permit the technician to set up the video levels more easily. It is suggested that this circuit take the form of a gate circuit which gates out the permanent echoes, a thresholding circuit, and a meter circuit which measures the percentage of time which the noise peaks exceed this threshold. The circuit would require about three tube envelopes.
- 2) The following controls on the video channels should be moved to the interior of the chassis or fitted with guards: Balance, Clip Level, and AJ Bias. These controls require adjustment perhaps once a week or month. Misadjustment of any of these controls due to an inadvertent slip by the technician requires a lengthy setup procedure.
- 3) The power supply should be fitted with a time delay relay so that the technician cannot switch on the high voltages without sufficient warm-up time for the heaters.
- 4) The circuitry providing addition of the video outputs of the two channels should be removed, as it offers no advantages in either the jammed or non-jammed environments.

ACKNOWLEDGEMENTS

The author wishes to thank S/L J. Fernie of the RCAF for originally suggesting the problem and for his and F/O Orr's, the RCAF project officer, aid in the development of the Unit. As NRC project officer, the author is indebted to the following for their excellent co-operation: Mr. K.J. Pindur of the National Research Council, Mr. J. Fisher of Canadian Arsenals Limited, and the personnel of RCAF Station Foymount and USAF Saratoga Springs Base.

REFERENCE

1. Hunt, F.R., "A Portable Receiver for Antenna Pattern Measurement", NRC Report ERB-458, February 1958.

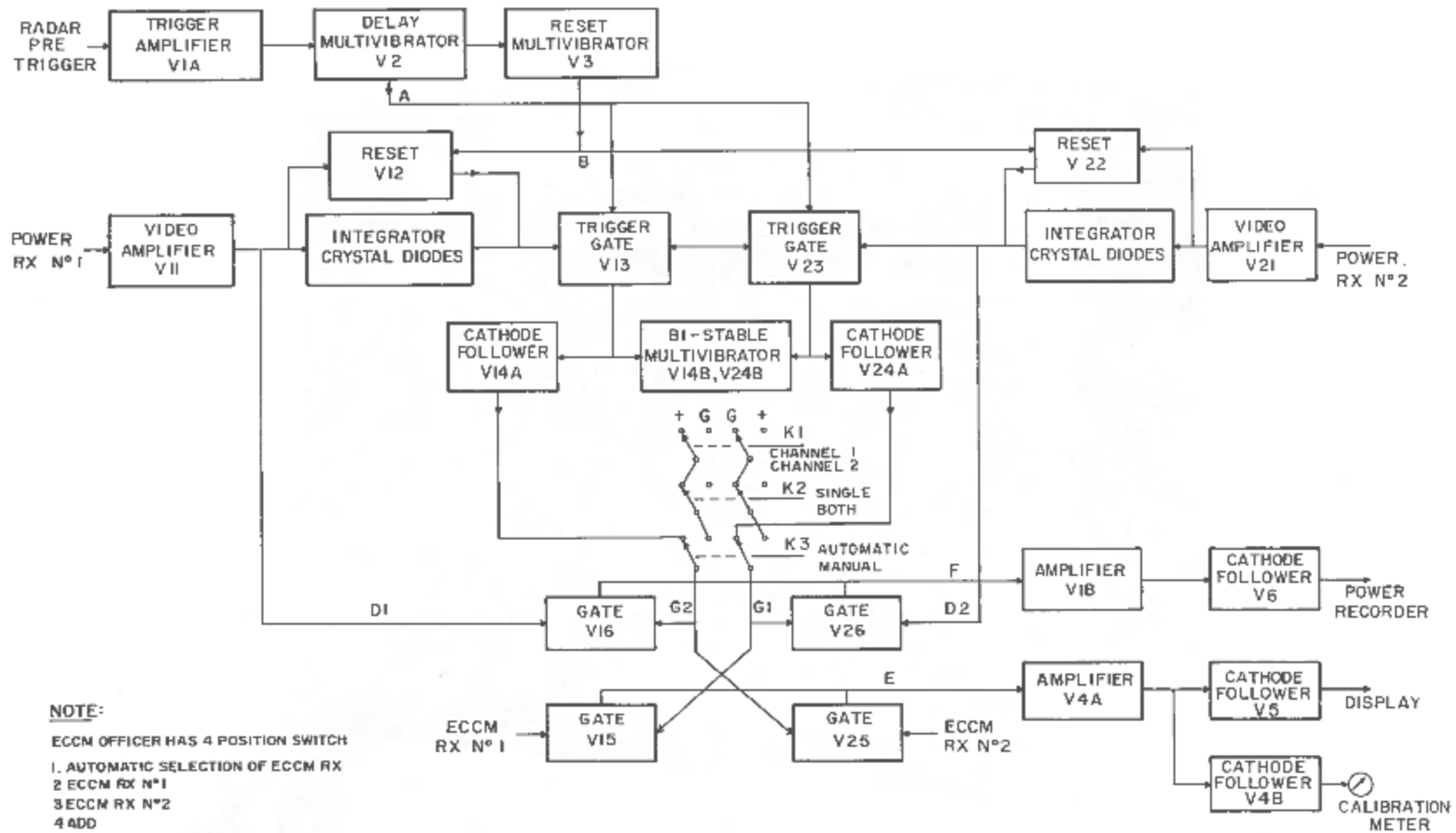

Fig. 1 Block diagram of duplex gating unit



Plate I — Experimental model of duplex gating unit



Plate II — Service test model of duplex gating unit
(Front open to show module construction)