

NRC Publications Archive Archives des publications du CNRC

The PC/104 Technology in Embedded System Janes, M.

For the publisher's version, please access the DOI link below. / Pour consulter la version de l'éditeur, utilisez le lien DOI ci-dessous.

Publisher's version / Version de l'éditeur:

<https://doi.org/10.4224/8894972>

Student Report; no. SR-2006-16, 2006

NRC Publications Archive Record / Notice des Archives des publications du CNRC :

<https://nrc-publications.canada.ca/eng/view/object/?id=22caabb7-7f63-42b1-96fa-47bcd465d87b>

<https://publications-cnrc.canada.ca/fra/voir/objet/?id=22caabb7-7f63-42b1-96fa-47bcd465d87b>

Access and use of this website and the material on it are subject to the Terms and Conditions set forth at

<https://nrc-publications.canada.ca/eng/copyright>

READ THESE TERMS AND CONDITIONS CAREFULLY BEFORE USING THIS WEBSITE.

L'accès à ce site Web et l'utilisation de son contenu sont assujettis aux conditions présentées dans le site

<https://publications-cnrc.canada.ca/fra/droits>

LISEZ CES CONDITIONS ATTENTIVEMENT AVANT D'UTILISER CE SITE WEB.

Questions? Contact the NRC Publications Archive team at

PublicationsArchive-ArchivesPublications@nrc-cnrc.gc.ca. If you wish to email the authors directly, please see the first page of the publication for their contact information.

Vous avez des questions? Nous pouvons vous aider. Pour communiquer directement avec un auteur, consultez la première page de la revue dans laquelle son article a été publié afin de trouver ses coordonnées. Si vous n'arrivez pas à les repérer, communiquez avec nous à PublicationsArchive-ArchivesPublications@nrc-cnrc.gc.ca.

DOCUMENTATION PAGE

REPORT NUMBER	NRC REPORT NUMBER	DATE	
SR-2006-16	SR-2006-16	May 8, 2006	
REPORT SECURITY CLASSIFICATION		DISTRIBUTION	
Unclassified		Unlimited	
TITLE			
The PC/104 Technology In Embedded System Design			
AUTHOR(S)			
Michael Janes			
CORPORATE AUTHOR(S)/PERFORMING AGENCY(S)			
PUBLICATION			
SPONSORING AGENCY(S)			
IMD PROJECT NUMBER		NRC FILE NUMBER	
421014			
KEY WORDS	PAGES	FIGS	TABLES
PC/104, industry profile, system components, embedded design	ii, 22, App. A-D	26	2
SUMMARY			
<p>This purpose of this report is to give the reader a background into the PC/104 industry and to act as a guideline and source for selecting PC/104 boards for IOT applications. It discusses the PC/104 industry and the use of PC/104 modules as system components. The first section gives a background and some insight into the PC/104 technology. Things like standardization, growth, market and future of the industry are discussed.</p> <p>The other section outlines various PC/104 modules that can be used in system design. Several products from four companies are discussed and the key features for each device are noted. Pricing and distributors of these products are outlined. I have made some recommendations for which products may be best based on my research into the industry.</p>			
ADDRESS	National Research Council Institute for Ocean Technology Arctic Avenue, P. O. Box 12093 St. John's, NL A1B 3T5 Tel.: (709) 772-5185, Fax: (709) 772-2462		



National Research Council Conseil national de recherches
Canada Canada

Institute for Ocean
Technology

Institut des technologies
océaniques

The PC/104 Technology In Embedded System Design

SR-2006-16

Michael Janes

May 2006

Acknowledgements:

Peter Hackett

Jim Williams

Tim Ennis

Vaughan Benson

Ed Kennedy

Jody Farr

David Millan

Greg Janes

TABLE OF CONTENTS

List of Figures	ii
1 PC/104 TECHNOLOGY	1
1.1 Introduction.....	1
1.2 Historical Perspective	1
1.3 About the Technology.....	3
1.4 The Need.....	4
1.5 Standardization	5
1.6 Growth and Versatility.....	5
1.7 Market.....	7
1.8 Future	9
2 PC/104 MODULES IN EMBEDDED SYSTEMS.....	10
2.1 CPU.....	11
2.2 Analog and Digital I/O.....	12
2.3 Ethernet.....	14
2.4 GPS Communications.....	15
2.5 Power Supplies.....	17
2.6 Cables and Accessories.....	18
2.7 Price Comparison.....	20
3 RECOMMENDATIONS	20
4 REFERENCES	22

APPENDIX A: Pricing Information

APPENDIX B: Datasheets

APPENDIX C: PC/104 Vendor List

APPENDIX D: Contacts

List of Figures

Figure 1-1: PC/104-Plus..... 3
Figure 1-2: PC/104..... 3
Figure 1-3: PCI-104 3
Figure 1-4: Stackable PC/104 Modules..... 6
Figure 1-5: PC/104 Modules in Component-Like Applications 6
Figure 2-1: RTD's PC/104-plus CPU 11
Figure 2-2: Diamond PC/104 CPU 11
Figure 2-3: Arcom PC/104 CPU 12
Figure 2-4: Micro/sys PC/104 CPU 12
Figure 2-5: RTD PC/104-plus DAS 13
Figure 2-6: Diamond PC/104 DAS 13
Figure 2-7: Arcom PC/104 DAS..... 13
Figure 2-8: Micro/sys PC/104 DAS 14
Figure 2-9: RTD PC/104-plus Ethernet Adapter 14
Figure 2-10: Diamond PC/104-plus Ethernet Adapter 15
Figure 2-11: Arcom PC/104 Ethernet Adapter 15
Figure 2-12: Micro/sys PC/104 Ethernet Adapter 15
Figure 2-13: RTD PC/104-plus Comm. Module 16
Figure 2-14: Diamond PC/104 Comm. Module 16
Figure 2-15: Arcom PC/104 Comm. Module..... 16
Figure 2-16: RTD PC/104-plus Power Supply..... 17
Figure 2-17: Diamond PC/104 Power Supply..... 17
Figure 2-18: Micro/sys PC/104 Power Supply..... 17
Figure 2-19: Morpheus Cable Kit..... 18
Figure 2-20:RTD PC/104plus Storage Module..... 19
Figure 2-21: RTD PC/104 Servo Motor Controller..... 19

1 PC/104 TECHNOLOGY

1.1 *Introduction*

Engineers are always looking for new and innovative ways to enhance and improve current technology and at the same time minimize the costs of production and maintenance. Debugging and verification are time-consuming tasks. Manufacturing processes using surface mount components are complex. Plus changes to the product specifications are inevitable. These factors have driven engineers to seek better solutions to design. One method that is growing in popularity is the use of PC/104 modules.

The PC/104 form factor was developed by Ampro Computers in California during the late 1980's. The specification was published in 1992 in order to enhance popularity. Now over 150 vendors manufacture PC/104 compatible products including controller cards, software, and accessories.

PC/104 can be used as components to make up a larger system. They have active and passive components mounted on circuit boards that are configured for a specific task. System components can be either single- or multi-function modules that serve as highly integrated building blocks of a system. A system component can be as simple as a digital I/O board or as complex as a computer with video, memory, networking, and I/O all on a single board. PC/104 boards support industry standards and are available from multiple sources worldwide.

1.2 *Historical Perspective*

Over the last 50 years, technology has progressed from tubes to transistors and then to integrated circuits. The early 1980's saw the dominance of large-scale integrated components that enabled the creation of microprocessors. The

PC/104 Technology in Embedded Systems

SR-2006-16

advances in semiconductor technology enabled engineers to increase the functional density on a board. At the same time, they were able to decrease cost and power requirements while increasing the reliability of circuit boards. As the pace of technology accelerated, the boards became more complex and difficult to design. Consequently, system design has changed dramatically over the years.

In the past, primary design factors were based on selecting the appropriate hardware components. Companies would routinely design their own systems because designing, manufacturing, testing, and software coding were relatively easy at the time. Time and money were available so even non-computer companies could use their own resources to design computers from chip-level to final product. Size, shape, CPU type, expansion modules, and coding varied greatly from one company to the next. There was not a need for industry-wide standards mainly because there were not a wide variety of off-the-shelf products to choose from. This resulted in a mess of hardware, software, and system designs based upon an engineer's personal preference.

Just recently, the advancements of silicone technology has changed the way companies select their system components. No longer does it only depend on the power and speed of the CPU available but things like software design, board size, and time-to-market are key factors in the decision making process. With the fast-paced world we live in, the amount of time available to develop an embedded system has decreased significantly with times now as short as 3 to 6 months. Designers had to adapt to this reality.

Presently, designers have turned to industry standards. No longer do companies develop in-house designs but rather they turn to open market products to speed their time-to-market. Nowadays, system components are available as higher-level logic functions such as the computer, video, network, memory and I/O. These functions are based upon industry standards to provide greater design flexibility and functionality in less volume and at a lower cost.

1.3 About the Technology

PC/104 is simply a repacked modular version of the PC. This technology makes great use of small (3.6 x 3.8 in), self stacking PC/104, PC/104-Plus or PCI-104 I/O modules with 104-pin ISA and / or 120-pin PCI bus connectors for I/O expansion. This unique stacking technology allows multiple modules to be added to the system without the burden of backplanes and card cages. Below you can see the fundamental difference between each of the three modules.



Figure 1-1: PC/104-Plus



Figure 1-2: PC/104



Figure 1-3: PCI-104

PC/104 modules consist of two adjacent buses. P1 bus has 64-pins just like the PC-XT and is combined with 40-pins on P2 for full AT-compatibility. The sum of the pins ($64 + 40 = 104$) is the origin of the name PC/104. For applications requiring greater throughput, PC/104-Plus was introduced. The PC/104-Plus modules allow the most system configuration flexibility. The PCI bus is the standard for desktop 32-bit transfers and significantly improves throughput between boards.

There are advantages to having both buses on the same module. PCI bus, for high speed block data transfers (e.g. video, networking, disk storage); and ISA bus, for byte-oriented (e.g. real-world data acquisition and control). There

PC/104 Technology in Embedded Systems

SR-2006-16

are many modules available with varying capabilities. Some of the different functional types are listed below.

- CPU
- DSP (Digital Signal Processing)
- Memory
- Mass storage control
- Graphics/Display/Video (including Frame Grabbers)
- Audio (including vocoders)
- Networking (including NPUs, Ethernet, Fieldbus adapters, ARINC, USB, Firewire)
- Analog/Digital I/O (including serial, parallel, A-D, D-A, counters, timers)
- Switch Fabric Access
- Motor Control
- Telecom Connectivity (includes modem, ATM, T1/E1, VoIP)

1.4 *The Need*

Like any invention or technology there has to be a need in order for it to be successful. PC's are not just used for desktop applications and have a much more broader use. A PC can be used as an instrumentation controller, a communication device, and a data acquisition system to just name a few. However, the standard PC bus form-factor (12.4" x 4.8") and its associated card cages and backplanes are too bulky and expensive for most embedded control applications.

A need therefore arose for a more compact implementation of the PC bus, satisfying the reduced space and power constraints of embedded control applications. Yet these goals had to be realized without sacrificing full hardware and software compatibility with the popular PC bus standard. This would allow the PC's hardware, software, development tools, and system design knowledge to be fully leveraged. In other words, the PC bus had to be standardized while capturing all of the benefits the design engineer wanted from the PC bus.

PC/104 Technology in Embedded Systems

SR-2006-16

PC/104 was developed in response to this need. It offers full architecture, hardware, and software compatibility with the PC bus, but in ultra-compact (3.6" x 3.8") stackable modules. PC/104 is therefore ideally suited to the unique requirements of embedded control applications - including full standardization by an international group of over 160 companies who manufacture products based on our PC/104 standard.

1.5 Standardization

Once regulations or standards were set in place for PC technology, embedded system designers could reduce costs, time, and risks involved using the technology. They need not be concerned with compatibility as standards are put in place to ensure a device from one PC can function properly on another PC. Because of industry standards, the growth and popularity of embedded PC's directly results from the ability of a user to buy off-the-shelf hardware and customize it with software.

The PC/104 Consortium, founded in 1991, was established to maintain the specifications, publish a resource guide, participate in standards activities, and to promote PC/104 at trade shows and through news releases. Initially released in 1992, the PC/104 standard document describes the technical details needed by engineers and programmers.

For full specifications on all PC/104 form factors please visit the following web address: http://www.pc104.org/technology/pc104_tech.html.

1.6 Growth and Versatility

PC/104 is an ideal system component for industrial applications. With today's standards, a designer can either design and build their own specialty I/O board in-house or find hundreds of vendors with countless number of products worldwide. It solves space and power-sensitive constraints, yet it does not sacrifice the architecture, hardware, and software capability of a true PC.

PC/104 Technology in Embedded Systems

SR-2006-16

The stacking nature of PC/104 boards permits more flexibility in design and expansion capability. This reduces cost and bulk and increases mounting and packaging options. In addition, four corner-mounting holes are included to attach metal or plastic threaded standoffs. They help form a sturdy mechanical structure that adds ruggedness for industrial applications subject to shock and vibration.

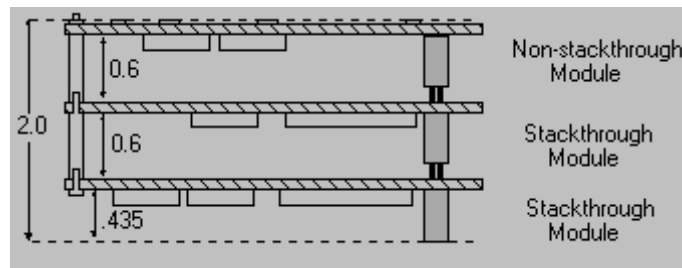

Figure 1-4: Stackable PC/104 Modules

Another way to use PC/104 modules is illustrated in Figure 1-5. In this configuration, the modules function as highly integrated components, plugged into custom carrier boards which contain application-specific interfaces and logic. The modules' self-stacking bus can be useful for installing multiple modules in one location. This facilitates future product upgrades or options, and allows temporary addition of modules during system debug or test.

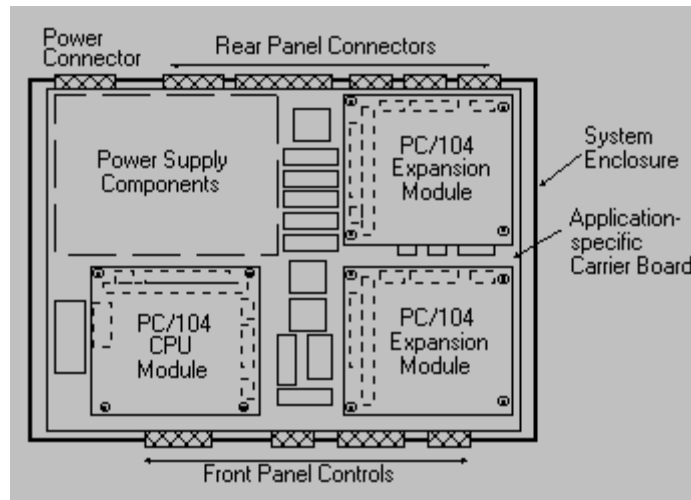

Figure 1-5: PC/104 Modules in Component-Like Applications

PC/104 Technology in Embedded Systems

SR-2006-16

The beauty of using PC/104 as a system component is the ability to use the same part in a variety of applications. Take a PC/104 CPU module for example. It is possible that the same system component is designed to work in many different applications like machine controllers, medical instruments, telecommunications, diagnostic equipment, remote network monitoring and reporting devices, security systems, weighing systems, and semiconductor processing equipment. Even though the products and companies differ, software and specialized I/O cards customize the CPU to suit their requirements.

The PC/104 module in system designs is growing in popularity. The reason for this is that it enables companies to focus upon its core competency by emphasizing areas where they can add value to existing designs rather than reinventing computer hardware again and again. Choosing PC/104 system components increases reliability and gets the product to the market quicker while making use of the vast software infrastructure supporting PC's. The bottom line is that the PC/104 module has become firmly established as a standard design component in a wide variety of industrial applications.

1.7 Market

An annual report by the Venture Development Corporation (VDC) claims that the most dramatic growth is projected for the new PCI-104 architecture, which does not include ISA expansion capability. Although comprising only 5.3% of shipments in 2004, PCI-104 is expected to reach a share of nearly 16% in 2008. This is equivalent to an increase of 331% in terms of dollar volume shipments. J. Eric Gulliksen, Embedded Hardware Practice Director at VDC says he "wouldn't be surprised to learn of a similar program to apply PCI Express to the PC/104 family form factor in the near future....This would provide for increased performance and reduced board complexity, and further solidify the position of stackable architectures in the embedded world."

PC/104 Technology in Embedded Systems

SR-2006-16

As you can see in Figure 1-6, PCI-104 is expected to grow over the next few years as the ISA bus becomes less common. In the PC/104 family the original ISA expansion bus still dominates, comprising over 62% of total shipments in 2004. However, there is a trend toward the faster PCI expansion bus employed on PC/104-Plus and PCI-104 boards, which are expected to command a 48% share in 2008.

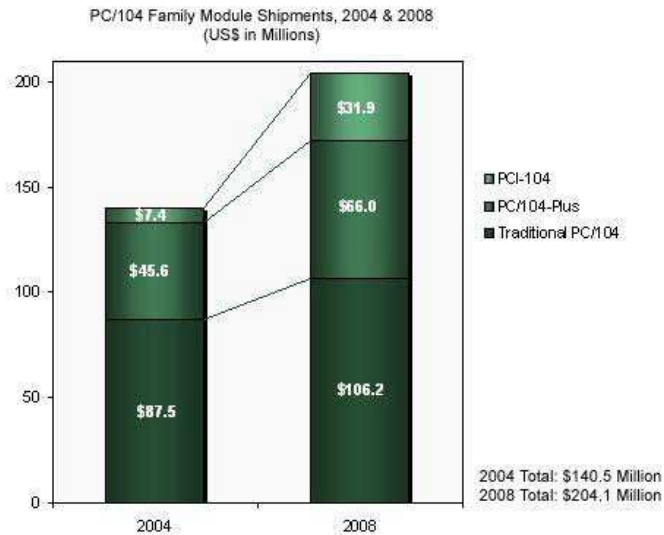

Figure 1-6: PC/104 Form-Factor Market Distribution

The report by VDC, *The 2004 Merchant Computer Boards for Embedded/Real Time Applications Market Intelligence Program Volume IV: Stackables*, highlights some interesting trends of PC/104 form factor boards. VDC expects that transportation equipment will comprise the third largest consuming vertical market for stackables after the Industrial Automation and Medical segments. Military/aerospace/defense market is considered the fourth largest consumer base. The following is a list of markets and applications that use this stackable technology:

- Communications - Automatic Call Distributor, gateways, PBX, SS7 control, Internet backbone switchers/routers
- Industrial Control and Automation - distributed control systems, motor/motion control

PC/104 Technology in Embedded Systems

SR-2006-16

- Instrumentation - automated test equipment, scientific instrumentation
- Medical – imaging, patient monitoring
- Military, aerospace, defense
- Transportation - mass transit, maritime navigation and control, air traffic control, on-board systems for heavy transport

Well known companies that use PC/104 include NASA, Lockheed Martin, Northrop Grumman, Boeing, Cooper Powertools, L-3 Communications, SAIC, Baxter Healthcare, Tyco, and Walt Disney.

1.8 Future

The future for PC/104 form factors is optimistic despite some challenges. Some companies are worried that since Microsoft has announced not to support the ISA Bus in the future that PC/104 is going to be incompatible with new technology. Intel and other companies have stepped up and promised to keep the ISA chipsets alive for at least five to seven more years. The ISA bus has been absent from consumer desktop computers for several years, but still finds utility in many Industrial Automation applications that do not require high-speed response. However, as demand for, and therefore the supply of, controller and bridge chips declines, ISA will continue to decline. There are many PC/104-based "real world" interfaces from hundreds of manufacturers, and these are not going to become obsolete just because the desktop PC does not require or use ISA slots anymore.

The PC/104 Consortium have put standards in place to ensure the long-term future of this technology. Manufacturers of PC/104 modules now have three choices from which to choose, all within the industry standard PC/104 form-factor: (1) ISA bus only; (2) PCI plus ISA buses; and (3) PCI bus only. Today, 80% to 90% of PC/104 form-factor modules are using ISA bus only. Within approximately five years, it is likely that there will be greater than 50% using the PCI bus. It will probably take ten years before the situation of today is reversed,

PC/104 Technology in Embedded Systems

SR-2006-16

with 80% to 90% of PC/104 form-factor modules using PCI bus only. Even so, ISA will still be supported on PC/104-*Plus* modules, ten years from now.

2 PC/104 MODULES IN EMBEDDED SYSTEMS

PC/104 modules are manufactured to serve a wide variety of functions. In this section, I have isolated four PC/104 manufacturers and highlighted some of the features of their respective modules.

Please note, these manufacturers offer a wide range for PC/104 boards serving a variety of functions. A list of website addresses and catalogue links can be found in Appendix B. Many systems used at IOT have the following system components:

- CPU
- Analog and Digital Input/Output Module
- Ethernet Adapter
- GPS Communication Device
- Power Supply

The following is a small of list of many manufacturers that design PC/104 computer boards:

- Real Time Designs (RTD)
- Diamond Systems
- Arcom
- Micro/sys

Table 1: PC/104 Part Numbers by Vendor

	RTD	Diamond	Arcom	Micro/sys
CPU	CME47786HX650	MOR-650	Viper	SBC1625
Analog/Digital Input/Output	SDM7540HR	DMM-32X-AT	AIM104-MULTI-I/O	MPC555
Ethernet	CM17202HR	MRC-100-XT	AIM104-ETHER	MPC356
GPS	COM17075ER	PXMM-GPS-XT	WEB-Telemetry-Ericsson	N/A
Power Supply	HPWR104plusHR	JMM-SIO-XT	N/A	PS104

PC/104 Technology in Embedded Systems

SR-2006-16

Appendix C contains a list of thirty five vendors of PC/104 products.

2.1 CPU

PC/104 CPU modules vary significantly from vendor to vendor. Clock speed, RAM, power requirement, and networking capabilities are just a few of the features that vary from board to board. It is important that you choose a CPU that will suffice for your application. The following briefly looks at similar CPU devices from each of the four companies noted above.

CME47786HX650

- 650 MHz Intel Celeron
- Up to 512MB SDRAM
- 9.0 W @ 5 VDC
- 2 RS-232/422/485 Ports
- 2 USB Ports
- EIDE Controller with UltraDMA 33/66/100
- Ethernet



Figure 2-1: RTD's PC/104-plus CPU

MOR-650

- 650 MHz Intel Celeron
- Up to 512MB RAM using DIMM
- 15.0 W @ 5VDC
- 1x RS-232, 1x RS-232/422/485
- 2 USB Ports
- IDE port with UDMA-33 capability
- Ethernet



Figure 2-2: Diamond PC/104 CPU

PC/104 Technology in Embedded Systems

SR-2006-16

Viper

- 400MHz Intel PXA255 Xscale
- 1.9W @ + 5VDC
- 5 Serial Ports
- Up to 64MB SDRAM
- 16 channel DMA controller
- 2 USB Ports
- Ethernet

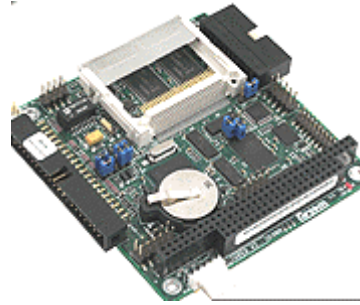

Figure 2-3: Arcom PC/104 CPU

SBC1625

- IXP425 XScale ARM 533MHz processor
- Dual 10/100BASE-T Ethernet
- 128MB SDRAM, 64MB Flash
- 4 Serial Ports
- 2 W @ +5VDC



Figure 2-4: Micro/sys PC/104 CPU

For much more in-depth information please see their respective datasheets. Locations of these datasheets on-line can be found in Appendix B.

2.2 Analog and Digital I/O

Analog and digital input and output devices are used to acquire and analyze data from the real world. Resolution, sampling rates, number of channels and power requirement are some key factors to consider when picking a device suitable for your application.

PC/104 Technology in Embedded Systems

SR-2006-16

SDM7540HR

- 12-bit A/D and D/A resolution
- 1.25 MHz input sampling rate
- 200 KHz output rate
- 8 differential or 16 single-ended inputs
- 8 programmable digital I/O lines
- 4.0 W @ 5 VDC

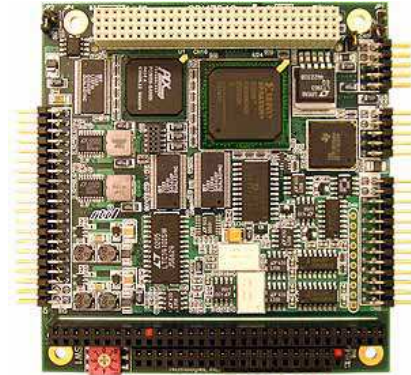

Figure 2-5: RTD PC/104-plus DAS

DMM-32X-AT

- 16-bit A/D and 12-bit D/A resolution
- 250 KHz input sampling rate
- 100 KHz output rate
- 32 analog inputs
- 24 programmable digital I/O



Figure 2-6: Diamond PC/104 DAS

AIM104-MULTI-I/O

- 12-bit A/D and D/A resolution
- 3.125 kHz input rate/channel
- 2 kHz output rate/channel
- 16 single-ended or 8 differential analog inputs
- 2.4 W @ 5VDC



Figure 2-7: Arcom PC/104 DAS

PC/104 Technology in Embedded Systems

SR-2006-16

MPC555

- 16 12-bit input channels
- 100 KHz A/D sampling rate
- Optional 12-bit DACs, 4 or 8 channels
- 24 Digital I/O lines
- 1.9W @ 5VDC max.



Figure 2-8: Micro/sys PC/104 DAS

2.3 Ethernet

Many PC/104 CPU modules have ethernet capabilities without the need for a separate ethernet adapter. However, sometimes they do not or depending on your application you may require multiple ethernet ports and controllers. The following summarizes four ethernet adapters from the companies I have focused on.

CM17202HR

- Intel 21143 PCI Fast Ethernet Controller
- 3.3V and 5V PCI signaling compatible
- RJ45 Connector
- 3.0 W @ +5 VDC



Figure 2-9: RTD PC/104-plus Ethernet Adapter

PC/104 Technology in Embedded Systems

SR-2006-16

MRC-100-XT

- 2 PCI-based 10/100 Ethernet ports
- RJ-45 and pin header Ethernet connections
- 24 digital I/O lines on ISA bus
- 1.4 W @ +5 VDC



Figure 2-10: Diamond PC/104-plus Ethernet Adapter

AIM104-ETHER

- RealTek RTL8019AS Controller
- 16-way AUI and RJ-45 10BaseT connections
- 8 Software configurable IRQ's
- 2.0 W @ 5VDC Max.



Figure 2-11: Arcom PC/104 Ethernet Adapter

MPC356

- Thin coax 10BASE-2 or twisted pair 10BASE-T connections
- IEEE 802.3 Ethernet standard
- Configurable I/O address, ROM address, and IRQ number
- 1.3 W @ 5VDC Max.



Figure 2-12: Micro/sys PC/104 Ethernet Adapter

2.4 GPS Communications

PC/104 GPS Modules can be very useful in embedded solutions. Some common applications include mobile telematics, mobile and vehicle systems,

PC/104 Technology in Embedded Systems

SR-2006-16

fleet management, distributed communication systems, and remote data logging nodes. The following looks at some GPS receiver modules and some of their key features.

COM17075ER

- Siemens MC75 based GSM/GPRS/EDGE modem
- Fastrax iTrax02 GPS receiver
- 16 TTL digital I/O: 8 outputs, 8 inputs
- 2.2W @ 5 VDC



Figure 2-13: RTD PC/104-plus Comm. Module

PXMM-GPS-XT

- Trimble Lassen SKII 8-ch. GPS receiver module
- MultiTech SocketModem
- Built-in TTL serial-to-PC/104 bus interface
- 2 W @ 5 VDC



Figure 2-14: Diamond PC/104 Comm. Module

WEB-Telemetry-Ericsson

- Trimble LassenSQ GPS module
- Sony Ericsson GM47/48 Cellular GPRS Modem
- 2 x RS232 D-sub 9 plugs, 1 x RJ45 LAN connector



Figure 2-15: Arcom PC/104 Comm. Module

2.5 Power Supplies

PC/104 also offers a variety of power supplies that can easily be incorporated into your embedded design. Maximum output about 10 W to as much as 100W or more. It is important that power can vary from you pick a power supply that meets the requirements of your application. The following looks at some power supply modules offered by the companies I focused on.

HPWR104plusHR

- 83W maximum output power
- 8-32 Vdc Unregulated DC input
- Efficiency as high as 90%
- Several output modes with overload and short circuit protection

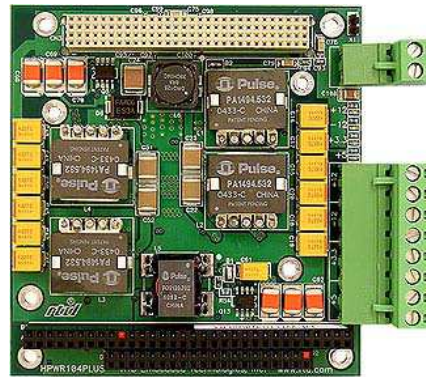

Figure 2-16: RTD PC/104-plus Power Supply

JMM-SIO-XT

- 50W output power
- 8-30VDC input range
- Efficiency from 80% - 92%
- Current limit/short circuit protection
- 2 serial ports, RS-232/422/485

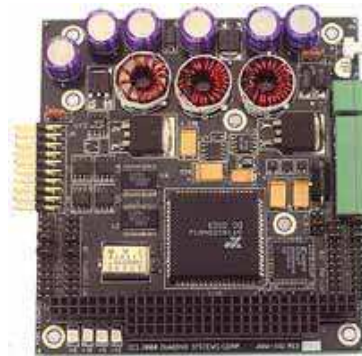

Figure 2-17: Diamond PC/104 Power Supply

PS104

- 9-18, 18-36, 36-72 Vdc input options
- Output and Input protection and filters
- Ultra-low noise design



Figure 2-18: Micro/sys PC/104 Power Supply

2.6 Cables and Accessories

Many of these modules come with their own cable or development kit. Just ask the manufacturer or supplier about these kits when ordering. For example Diamond Systems supplies a cable kit for their Morpheus CPU.

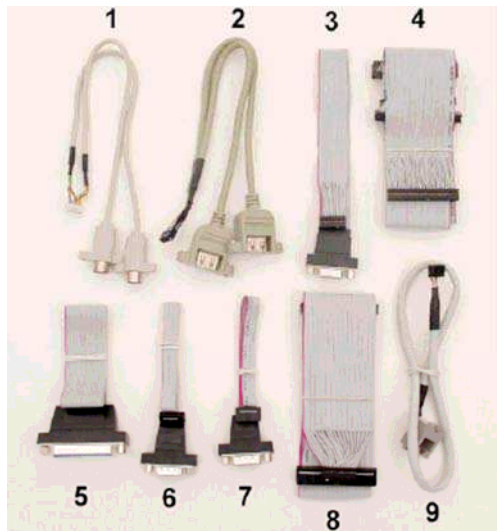

1. Keyboard and mouse cable
2. USB cable
3. VGA cable
4. IDE cable
5. Parallel port cable
6. Serial port cable
7. Serial port cable
8. Floppy drive cable
9. Ethernet Cable

Figure 2-19: Morpheus Cable Kit

Many embedded systems need things like mass storage devices and motion controllers. RTD has a wide variety of mass storage devices. RTD makes a *PC/104-Plus* Dual-slot CompactFlash Controller with External IDE connector (CMT7118HR).

PC/104 Technology in Embedded Systems

SR-2006-16

Some features of CMT7118HR:

- Dual CompactFlash sockets configurable with Master/Slave jumpers
- External 0.1" connector for connecting up to 2 IDE devices
- Transfer rates up to UltraDMA133
- Supports booting to CompactFlash and IDE devices

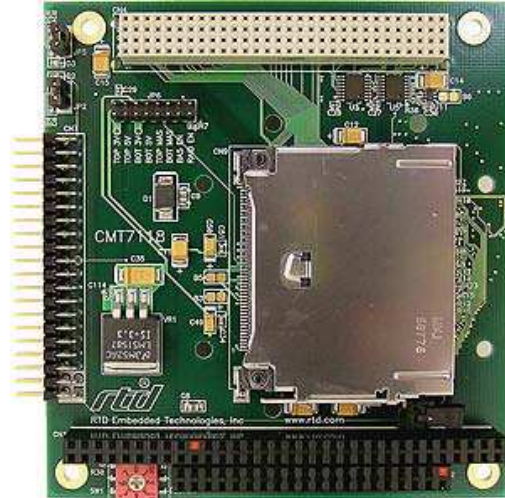

Figure 2-20:RTD PC/104plus Storage Module

RTD also manufacturers a PC/104 style Servo Motor Controller (ISC629ER).

Some features of ISC629ER:

- Two independent motor interfaces
- Position, velocity, acceleration
- Two full bridges for direct motor connection
- 60V, 10A onboard MOSFET H-bridges
- 24 TTL I/O, 8255 based
- 2.0 W @ 5 VDC typical - will increase with motor drive current

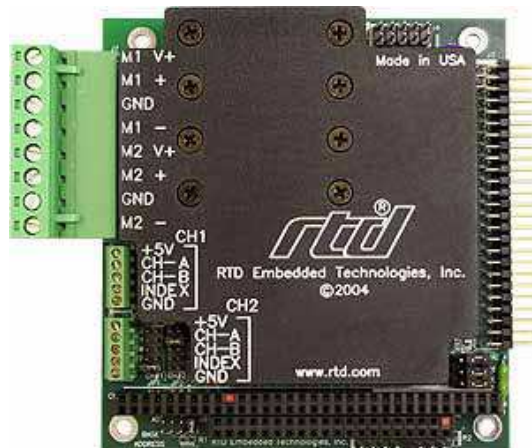

Figure 2-21: RTD PC/104 Servo Motor Controller

The scope of this section is fairly small considering the wide range of products available. It is best that you refer to the manufacturers website to look for the features you want to add-on to your specific system.

2.7 Price Comparison

As you can see in Table 2, the prices of PC/104 modules range significantly from vendor to vendor. At first, it looks like RTD is much more expensive than its competitors. But upon closer examination of datasheets and manuals, you can see that some of these modules are more sophisticated and have features that the others do not. It really depends on what you require for your specific application. This is simply meant as a guide to helping you pick the right device for your design. For example, you may want highly accurate and precise data acquisition system. Therefore, a more expensive and complex module like that supplied by Diamond or RTD may be best for the application.

Table 2: Product pricing by vendor (US Dollars)

	RTD	Diamond	Arcom	Micro/sys
CPU	\$795 - \$1145	\$340 - \$500	\$495	\$550 - \$625
Analog/Digital Input/Output	\$1395	\$595	\$285	\$265 - \$450
Ethernet	\$295	\$110	\$109	\$205
GPS	\$695	\$225	\$243	N/A
Power Supply	\$495	\$275	N/A	\$195 - \$295

For more on product information and pricing visit the following links for complete product catalogues:

RTD: http://www.rtd.com/catalog/RTDSHFORM-USA-0306_WEB-letter.pdf

Diamond: <http://www.diamondsystems.com/files/binaries/DSC-2006-04-Catalog.pdf>

3 RECOMMENDATIONS

The use of PC./104 modules as system components is a great way to cut down on size, space, time, and power required. There are many boards ranging in functionality, price, and complexity. It is the responsibility of the system designer or application engineer to decide which modules and to what degree of complexity would be best for their system.

Some vendors and manufacturers appear to be ahead of the game. RTD offers most of their boards in the PC/104-plus form factor. The PC/104 industry

PC/104 Technology in Embedded Systems

SR-2006-16

is leaning more and more towards the 120-pin PCI bus connector. There are advantages to each of these busses, but having both installed on your PC/104 board makes your system that much more dynamic.

Diamond and RTD both have several distributors located in Canada. This will most likely cut-down on lead times and product pricing. Although companies like Arcom and Micro/sys have valuable products, their scope is much more narrow than that of the bigger companies like Diamond and RTD. There are many vendors out there that develop PC/104 boards for a specific purpose. It is recommended that you view the vendor list in Appendix C as a guide in finding the boards which suit your application.

For more on vendor and distributors contact information see Appendix D.

4 REFERENCES

- Venture Development Corporation 2004. *The 2004 Merchant Computer Boards for Embedded/RealTime Applications Market Intelligence Program Volume IV: Stackables*. Available from <http://www.vdc-corp.com/embedded/annual/05/br05-05a.html> via the Internet. Accessed March 2006.
- PC/104 Consortium (2006). Available from <http://www.pc104.org> via the Internet. Accessed March, 2006.
- RTD Embedded Technologies, Inc. (2005). *PC/104 & PC/104-plus Product Menu* [WWW document]. URL <http://www.rtd.com/PC104/pc104menu.htm>
- Diamond Systems (2006). *PC/104 Product Catalog* [WWW document]. URL <http://www.diamondsystems.com/products/>
- Micro/sys (2006). *Embedded System Products from Micro/sys* [WWW document]. URL <http://www.embeddedsys.com/subpages/products/products.shtml>
- Arcom (2006). *Product Range* [WWW document]. URL <http://www.arcom.com/products/overview/default.htm>

APPENDIX A:
Pricing Information

Price Quote E-Mail from Tri-M Systems, a vendor of Diamond products:

From: Meyer Toole [meyer@tri-m.com]
Sent: April 5, 2006 5:21 PM
To: Janes, Michael
Subject: Diamond Systems Products

Hello Michael:
Thank you for your email.
Here are the prices for the other items you requested.
Ethernet: MRC-100-XT
\$110.00
Power Supply: JMM-SIO-XT
\$275.00
Analog/Digital I/O: DMM-32X-AT
\$595.00
Digital I/O: ONYX-MM
OMM-XT Onyx-MM 48 digital I/O + 3 counter/timers extended temp. \$169 OMM-DIO-XT Onyx-MM 48
digital I/O only extended temperature \$89
GPS: PXMM-GPS-XT
\$225.00
Extra's: ACC-HDDMOUNT \$25.00
 ACC-CFEXT \$35.00
 MEM-512-01 \$160.00

Again, our prices are in U.S. Dollars, FOB Tri-M Systems.
We can also invoice in Canadian Dollars.

If you have any other questions or would like to place an order, please feel free to contact me.

Regards.
Meyer Toole
Tri-M Systems

Toronto Office:416-221-0910

Subject: RE: Diamond Systems Products
Date: Wed, 5 Apr 2006 08:23:58 -0400
From: "Janes, Michael" <Michael.Janes@nrc-cnrc.gc.ca>
To: "Meyer Toole" <meyer@tri-m.com>

Hello Meyer, I justed wanted to follow up on your e-mail and get a few more prices on some Diamond PC104 Modules.

Ethernet: MRC-100-XT
Power Supply: JMM-SIO-XT
Analog/Digital I/O: DMM-32X-AT (or DMM-32-AT)
Digital I/O: ONYX-MM
GPS: PXMM-GPS-XT
Extra's: ACC-HDDMOUNT
 ACC-CFEXT
 MEM-512-01

Thanks again!

Michael Janes
National Research Council

Institute of Ocean Technology
Phone: 709-772-7974
Fax: 709-772-2462

-----Original Message-----

From: Meyer Toole [mailto:meyer@tri-m.com]
Sent: April 4, 2006 6:20 PM
To: Janes, Michael
Subject: Diamond Systems Products

Hello Michael:

Your email has been forwarded to us by Diamond Systems, as we distribute these parts in Canada.

Our warehouse is in B.C. and I am located in Toronto.

You can see our products at - www.tri-m.com

Here are the prices for the items you requested.

MOR-400 Morpheus PC/104 CPU, Celeron 400MHz \$279.00 MOR-650 Morpheus
PC/104 CPU, Celeron 650MHz \$340.00

Our prices are in U.S. Dollars, FOB Tri-M Systems.

We can also invoice in Canadian Dollars.

If you have any other questions or would like to place an order, please feel free to contact me.

Regards.

Meyer Toole
Tri-M Systems

Toronto Office:416-221-0910

>Shipping Info:

>-----

>Name: Janes, Michael
>Company: NRC
>Email: Michael.Janes@nrc-cnrc.gc.ca
>Phone: 709-772-7974
>Fax: (none)

>

>Requested shipping location:

>Mun Campus
>St. John\'s, NL a1b 2a1
>Canada

>

>Customer comments:

>-----

>

>REQUESTED ITEMS:

>-----

>

>Morpheus: MOR-400
>Morpheus CPU, 400MHz / fanless, 0MB RAM
>Quantity: 1

>-----

>Morpheus: MOR-650
>Morpheus CPU, 650MHz / fan, 0MB RAM
>Quantity: 1

>-----

APPENDIX B:
Datasheets

RTD DATASHEETS AND MANUFACTURERS PRICING CAN BE FOUND AT FOLLOWING LOCATIONS:

CME47786CX650HR - <http://www.rtd.com/PC104/CM/786/47786/CME47786CX-650.htm>
SDM7540HR - <http://www.rtd.com/PC104/DM/analog%20IO/sdm7540.htm>
CM17202HR - <http://www.rtd.com/PC104/UM/network/cm17202.htm>
COM17075ER - <http://www.rtd.com/PC104/UM/modem/COM17075.htm>
HPWR104plusHR - <http://www.rtd.com/PC104/UM/power/hpwr104PLUS.htm>

DIAMOND DATASHEETS AND PRODUCT INFO FOUND AT FOLLOWING LOCATIONS:

MOR-650 - <http://www.diamondsystems.com/products/morpheus>
DMM-32X-AT - <http://www.diamondsystems.com/products/dmm32x>
MRC-100-XT - <http://www.diamondsystems.com/products/mercator>
PXMM-GPS-XT - <http://www.diamondsystems.com/products/pyxismm>
JMM-SIO-XT - <http://www.diamondsystems.com/products/jupitermmsio>

MICRO/SYS DATASHEETS AND PRODUCT INFO FOUND AT FOLLOWING LOCATIONS:

SBC1625 - <http://www.embeddedsys.com/subpages/products/sbc1625.shtml>
MPC555 - <http://www.embeddedsys.com/subpages/products/mpc555.shtml>
MPC356 - <http://www.embeddedsys.com/subpages/products/mpc356.shtml>
PS104 - <http://www.embeddedsys.com/subpages/products/PS104.shtml>

ARCOM DATASHEETS AND PRODUCT INFO FOUND AT FOLLOWING LOCATIONS:

Viper - <http://www.arcom.com/pc104-xscale-viper.htm>
AIM-MULTI-IO - <http://www.arcom.com/products/icp/pc104/modules/AIMmulti.htm>
WEB-Telemetry - http://www.arcom.com/products/icp/pc104/modules/WEB_telemetry.htm
AIMEther - <http://www.arcom.com/products/icp/pc104/modules/AIMether.htm>

Visit the following links for complete product catalogues:

RTD: http://www.rtd.com/catalog/RTDSHFORM-USA-0306_WEB-letter.pdf

Diamond: <http://www.diamondsystems.com/files/binaries/DSC-2006-04-Catalog.pdf>

APPENDIX C:
PC/104 VENDOR LIST

PC/104 VENDOR LIST IN REVERSE ALPHABETICAL ORDER:

WinSystems

Founded in 1982, WinSystems specializes in designing and manufacturing embedded computers and is recognized as a leading supplier of PC/104 products. The company has gained an excellent customer-oriented reputation for innovative design, engineering skills, and outstanding technical support.

WDL Systems

Offering a full line of embedded products and services to the embedded marketplace.

VersaLogic Corp

Visit VersaLogic's web site to see their complete line of PC/104, PC/104-Plus, and EBX products. Products include 586 to Pentium III Single Board Computers and a wide range of expansion modules. Voted PLATINUM embedded board vendor (2001-2002 Venture Development Corporation study.)

Tri-M Systems/Engineering Inc.

Designer, manufacturer and distributor of hardware solutions for embedded systems. Single board computers, power supplies, flash memory, data acquisition, enclosures, LCD displays, pointing devices, GPS and wireless devices for the OEM and engineering community.

Teka Interconnection Systems

Exclusive manufacturer of PC/104 and PC/104-*Plus* self-soldering connectors.

SECO srl

Design and manufacturer of Embedded PC, PC/104 and PC/104 Plus modules, Single Board Computers, Custom design, Windows CE development.

Sealevel Systems

Designed to meet the core needs of PC/104 applications requiring high reliability, long-term availability, and Windows and Linux support, Sealevel PC/104 modules offer easy serial, digital, and analog expansion.

SBS Technologies, Inc.

A world leader in the design and manufacturing of MIL-STD-1553 and ARINC 429 interface modules and bus analysis systems.

RTD Embedded Technologies, Inc.

PC/PCI-104 CPU and data acquisition modules and systems with advanced digital I/O, Intel Pentium, AMD and Via processors. Smart dataModules feature auto-cal, TI DSP's and hi-speed A/D - D/A converters. Peripherals include video, frame grabbers, mass storage and power supplies, wireless com and GSM/GPRS/GPS. Enclosed off-the-shelf and customized systems for demanding applications. Comprehensive drivers and example programs for Windows, Linux, DOS and RTOSes.

Parvus Corporation

An industry leader in rugged PC/104 and PC/104-Plus single board computers, power supplies, I/O & datacom modules, enclosures, and systems integration.

Octagon Systems

The market leader in reliable computers for rugged applications. CPUs and expansion cards for PC/104 and other formats. - 40C to 85C, off-the-shelf products. ISO 9001 since 1993.

OceanServer Technology, Inc.

Lithium-Ion battery based power supplies in PC/104 format; pre-engineered regulated or unregulated power sub-system makes any device portable such as robotics, autonomous instruments and embedded computers.

Micro Technic

Micronix PC/104 represents a comprehensive line of digital and analogue I/O boards, power supply and communication modules. All designed for industrial control systems and for mobile applications. NEW: Online ordering system using all major credit cards and quotation facilities in our webshop.

Micro/sys, Inc.

Micro/sys is a leading designer and manufacturer of embedded single board computers, microcontrollers, and expansion modules in PC/104, PC/104-Plus, EPIC™, EBX, STD, and custom formats. Processors range from 8051 through Pentium, including extended temperature operation. Micro/sys integrates the maximum amount of I/O onto each board, making solutions compact and cost effective, with extensive software support.

Microcomputer Systems, Inc.

PC/104 cards, custom designs, STD cards, ISA cards.

Megatel Computer (1986) Corporation

Specializes in designing and manufacturing embedded PC/104 and small format single board, PC compatible computers for the OEM. PC104, 4x4 SBCs are built to order.

LIPPERT Automationstechnik GmbH

LIPPERT designs and manufactures PC/104 x86 CPUs, from low power Geode GX1 up to Ultra Low Power Pentium III @650MHz. Complete Single Board Computers with VGA, FlatPanel, LVDS, TV OUT, one or two 10/100BaseT, Sound I/O, Flash Sockets, USB and more. Custom Designs are also available.

E-Zine of PC/104 Controlled Systems at <http://www.controlled.com/pc104>

An on-line E-Zine focused on PC/104 systems, vendors, products, news, Consortium info, and more.

Jacyl Technology, Inc.

Jacyl Technology specializes in the design and manufacture of FPGA, FPAA and Microprocessor based PC/104 circuit boards and provides custom electronic design services. We offer market driven solutions and value to our customers.

ICOP Technology, Inc.

Designs and manufactures Embedded PC using x86 SoC (Single-On-Chip) with DMP6117D and Vortex86 technology, ICOP offers custom design of Mity-Mite, Tiny/Embedded PC and PC/104 module, provider of BSP (Board Support Package) for WinCE.NET and Embedded XP, Embedded BIOS for quick boot up time.

EuroTech SpA

Eurotech, established in 1992, is today a leader in the field of Embedded Computer Technology (ECT). In addition to computer design and development, Eurotech is a one-stop site for the custom design of embedded PCs and high-performance embedded system. Eurotech offers a complete range of products and services, supplying a broad spectrum of industries, including transportation, telecommunication, security technology, aerospace and manufacturing industries.

ept

Pressfit Connectors for PC/104 systems, including PC/104 Plus in long and short tails, headers and shrouds. Support fixtures and press with tooling packages available.

EINDOS

EINDOS specializes in the design of Embedded Control and High Technology Hardware along with distribution and manufacturing. Products include PC/104 Modules, ETX systems, solid state disks, custom designs, and rugged, low-power industrial and military products.

E.E.P.D GmbH

Highest integrated mobile Pentium III PC/104-plus single-board-computer with ultra low power requirements. Low-Power Pentium 266 all-in-one CPUs with Graphic and Ethernet. Graphic, Ethernet and Multi I/O boards. Extended lifetime availability for all products. ISO 9001 certified.

Diamond Systems

Leading supplier of PC/104 and PC/104-expandable CPU, data acquisition, serial port, and power supply modules to the embedded market. The company also designs custom CPU and I/O boards.

Datasound Laboratories Ltd.

Datasound Laboratories Ltd. design & supply a complete range of PC/104, Compact PCI EBX and custom form factor products and provide full free of charge hardware & software technical support for the duration of your project.

Connect Tech

Designs and manufactures quality communications products including multi-port serial boards, Ethernet-to-serial devices, design and debugging tools and wireless radio modems. Over 20 years of experience in custom hardware/software design and off-the-shelf products for PCI, Universal PCI, PCI Express, CompactPCI, PC/104, PC/104-Plus, USB and ISA bus architectures.

Blue Chip Technology

UK based designer and manufacturer of industrial PCs and embedded boards. Off the shelf range of PC104, PC104+ boards, development kits and full custom development service.

Arcom

Arcom designs and manufactures a wide range of x86 and XScale based PC/104 boards, EBX format single board computers (SBCs) and PC/104 I/O modules. These are supported by the widest selection of ready-to-run Development Kits for Windows CE .NET, XP Embedded, Embedded Linux, VxWorks, QNX Neutrino, eCos and ROM-DOS.

Aprotek

A USA manufacturer of PC/104 and PC/104Plus modules, specializing in modems.

Apex Embedded Systems

Delivering a higher standard in ruggedized COTs PC/104 products including PC/104 data acquisition, analog I/O cards, high-current output digital I/O cards, and custom designs.

Advantech Embedded Computing

A leading manufacturer of the most advanced x86 architecture technologies including Biscuit SBCs, Half-sized CPU Cards, Full-sized CPU Cards, PC/104 Modules, POS Control Boards, Solid State Disks and industrial-grade Panel PCs. We also offer Embedded Operating Solutions including WinCE, WinCE .Net & Windows XPE. Our PC/104 peripheral modules include PCMCIA, Ethernet, GPS, Multi-port RS-232/422/485, Digital Input/Output, Analog-Digital converters, and a full series of CPU modules.

Advanced Micro Peripherals Ltd.

Ultra low power Transmeta Crusoe PC/104+ Computers, Video Capture, Video Annotation, MPEG Video Encode/Record/Streaming/Decode/Playback, HDLC/SDLC Comms.

Advanced Digital Logic, Inc.

Embedded and Stand-Alone PC/104 modules for OEMs and Application Developers ranging from 386 up to P5 as well as Ethernet, PCMCIA, CAN, Serial, Flash, VGA/LCD, and Sound peripherals.

ACCES I/O Products, Inc.

Analog, digital, serial communication and isolated I/O boards and solutions. ACCES also offers complete systems, integration services, and enclosures. Our products are designed for use with PC/104, PC/104-Plus, EBX, EPIC, PCI, Low Profile PCI, USB, Ethernet and ISA buses as well as distributed and wireless I/O.

AAEON Electronics, Inc.

AAEON is a TL 9000/ISO-9001 certified manufacturer of innovative X86- architecture Single Board Computers. We design and manufacture Half-size, Full-size, Compact, SubCompact, Media PC, Embedded Motherboards and PC/104 single board computers and I/O modules. We feature industrial PC Chassis; and offer multiple OS support. ODM/OEM projects and system integration opportunities are also welcome.

APPENDIX D:
CONTACTS

VENDOR	DISTRIBUTOR
<p><u>RTD:</u> Tel: 814-234-8087 Fax: 814-234-5218 Sales: sales@rtd.com Technical Support: techsupport@rtd.com Web: www.rtd.com</p>	<p><u>TRACAN ELECTRONICS CORPORATION:</u> Tel: 800-387-3268 Sales: sales@tracan.com 5 locations in Canada: BC, Alberta, Quebec, Ottawa, Toronto Web: www.tracan.com</p>
<p><u>Diamond Systems:</u> Tel: 650-810-2500 Fax: 650-810-2525 Sales: sales@diamondsystems.com Technical Support: techinfo@diamondsystems.com Web: www.diamondsystems.com Kurt Kleinschmidt: kurt@diamondsystems.com</p>	<p><u>Integrys Limited:</u> Tel: 905-502-2070 Fax: 905-890-1959 Sales: integrys_sales@aca.ca 5 locations in Canada: BC, Alberta, Montreal, Ottawa, Toronto Web: www.integrys.com</p> <p><u>Tri-M Systems:</u> Tel: 604-945-9565 Fax: 604-945-956 Meyer Toole: meyer@tri-m.com Eugene Leong: eleong@tri-m.com Web: www.tri-m.com</p>
<p><u>Arcom:</u> Toll Free: 888-941-2224 Telephone: (913) 549-1000 Main Fax: (913) 549-1001 Sales Fax: (913) 549-1002 Sales: us-sales@arcom.com</p>	
<p><u>Micro/sys:</u> Tel: 818-244-4600 Fax: 818-244-4246 Sales: TechSales@embeddedsys.com Technical Support: TechSupport@embeddedsys.com Rose Walker Amescua: tamescua@embeddedsys.com</p>	
<p><u>Winsystems:</u> Jeff Childs: jeff@winsystems.com (Appl. Engineer)</p>	