

NRC Publications Archive Archives des publications du CNRC

Weak thermal points or thermal bridges

Berthier, J.; National Research Council Canada. Division of Building Research

For the publisher's version, please access the DOI link below./ Pour consulter la version de l'éditeur, utilisez le lien DOI ci-dessous.

Publisher's version / Version de l'éditeur:

<https://doi.org/10.4224/20338011>

Technical Translation (National Research Council Canada); no. NRC-TT-1143, 1964

NRC Publications Archive Record / Notice des Archives des publications du CNRC :

<https://nrc-publications.canada.ca/eng/view/object/?id=8aabb173-9a3c-4a50-803d-870e017e831e>

<https://publications-cnrc.canada.ca/fra/voir/objet/?id=8aabb173-9a3c-4a50-803d-870e017e831e>

Access and use of this website and the material on it are subject to the Terms and Conditions set forth at

<https://nrc-publications.canada.ca/eng/copyright>

READ THESE TERMS AND CONDITIONS CAREFULLY BEFORE USING THIS WEBSITE.

L'accès à ce site Web et l'utilisation de son contenu sont assujettis aux conditions présentées dans le site

<https://publications-cnrc.canada.ca/fra/droits>

LISEZ CES CONDITIONS ATTENTIVEMENT AVANT D'UTILISER CE SITE WEB.

Questions? Contact the NRC Publications Archive team at

PublicationsArchive-ArchivesPublications@nrc-cnrc.gc.ca. If you wish to email the authors directly, please see the first page of the publication for their contact information.

Vous avez des questions? Nous pouvons vous aider. Pour communiquer directement avec un auteur, consultez la première page de la revue dans laquelle son article a été publié afin de trouver ses coordonnées. Si vous n'arrivez pas à les repérer, communiquez avec nous à PublicationsArchive-ArchivesPublications@nrc-cnrc.gc.ca.

PREFACE

The term "thermal bridge" is often used to describe those locations in the enclosure of a building through which heat is conducted more easily than through adjacent construction. In general this occurs where materials of relatively high thermal conductance provide a low resistance path for heat flow from inside to outside. In a heated building during cold weather, the inside surface temperature at a thermal bridge is lower than that of the surrounding construction and this is usually more serious than the additional heat loss. The low surface temperature may result in condensation on the surface, or require a low inside humidity in order to avoid such condensation. The variations in surface temperature due to the presence of the thermal bridge may also cause undesirable dust marking, since the rate of deposition of dust on a surface is a function of the difference in temperature between air and surfaces. Thermal bridges are thus particularly significant in cold climates, such as exist during the winter for most parts of Canada.

For some buildings thermal bridges may not present any serious problem, but for the majority it is important to at least recognize the limitations which they impose. In buildings where even moderate humidities must be maintained, it is imperative to eliminate thermal bridges; thus a knowledge of their characteristics is required. Unfortunately, heat flow in the vicinity of thermal bridges is complex and in many cases the most practical method of obtaining the required information is by direct measurement. For this reason, information is still inadequate.

Thermal bridges may take many forms. The Division has made extensive studies of thermal bridges associated with studding of conventional insulated wood-frame construction and with metal frames and sash of windows. Another important type of thermal bridge is associated with structural steel or concrete framing, and it is mainly with this type that this paper by J. Berthier of C.S.T.B. deals. The translation includes only Parts 1 and 2 of the paper, describing the results of laboratory measurements, since these are of particular interest to the Division.

The Division is grateful to Mr. D.A. Sinclair of the N.R.C. Translations Section for preparing this translation.

Ottawa
August 1964

N.B. Hutcheon
Assistant Director

NATIONAL RESEARCH COUNCIL OF CANADA

Technical Translation 1143

Title: Weak thermal points or thermal bridges
(Les points faibles thermiques ou ponts thermiques)

Author: J. Berthier

Reference: Cahiers du Centre Scientifique et Technique du Bâtiment, (334):
1-20, 1960

Translator: D.A. Sinclair, Translations Section, N.R.C. Library

FOREWORD

The following is a report on a new stage in the researches undertaken by the Centre Scientifique et Technique du Bâtiment (C.S.T.B.) on what we call the "hygrothermal characteristics" of external walls, i.e. the characteristics involved in problems of humidity and heat.

The first researches dealt with the resistance of walls to rain; the results were published in our Cahiers (No. 178, Section 19): "Resistance of porous materials to rain" (whole bricks, concrete blocks, soft limestone) and (No. 312, Section 39): "Some results of rain tests on light masonry" (with or without coating). These investigations made it possible to develop testing methods: "Research and checking tests approved by C.S.T.B." (Cahier No. 312, Section 39), to which reference has been made in the acceptance resolutions, especially with reference to the capillarity requirements under pressure of wall materials.

The investigations were then directed to the U values of walls. The results were published under the title: "Recommendations for the use of light masonries" (hollow terra cotta blocks, concrete blocks, light tamped concrete, autoclaved cellular concrete) Cahier No. 34, Section 287. Here we find first a report on tests ending with the determination of "useful U" values, i.e. U values of walls taking into account their moisture content. We then find recommendations establishing maximum admissible U values, and hence minimum thicknesses of walls, with special reference to the dangers of surface condensation depending on the rating of the equipment and occupation of the building.

The investigations described here concern the weak thermal points, commonly known as thermal bridges. They owe their origin to the desire to combat surface condensation. In Part III precise, quantitative recommendations are made concerning means of reducing the effects of weak thermal points in heavy concrete frame walls. It was possible to establish only general principles for thin light walls with wooden or metal framing. The particular case of walls with air gaps has not been dealt with.

Investigations are now underway on air gaps in walls and roofs with two objectives: to combat condensation in the wall material, and to provide protection against insolation. The former problem has already been touched on in connection with roofs in Cahier No. 31, Section 259 "Condensation below self supporting aluminium roofings".

A summarization and synthesis of these various investigations will be found in Vol. II of the R.E.E.F.-58, the chapter on "Hygrothermics and ventilation.

M. Croiset

Chief of the Division "Hygrothermics of Materials"

Table of Contents

Introduction	5
Part I, Qualitative approach to the problem by semi-natural tests	
Principle of semi-natural tests	8
Results	9
Part II, Quantitative study - artificial tests	
Characteristics of a thermal bridge	9
Test method	10
Choice of types of thermal bridges	12
Heavy walls	13
Light walls (curtain walls, façade panels)	16
Results	17
Heavy walls	17
Light walls (curtain walls, façade panels).....	20
References	24
Tables	25
Figures	31

WEAK THERMAL POINTS OR THERMAL BRIDGES

Summary

Uniformity of temperature on the internal surface is one of the essential hygrothermal characteristics of a wall.

The weak thermal points, which are the cause of uneven temperatures, constitute a weakness which ought to be eliminated.

The author describes a large number of tests carried out with various types of wall (dense walls and lightweight panels) in order to assess the importance of thermal bridges and to determine the effectiveness of possible remedies. He shows that the accepted theory used in the calculation of U values is unsatisfactory when estimating surface temperatures. The results obtained can be explained, however, by two simple hypotheses. From these, practical rules are derived by which the effect of a thermal bridge can be estimated, and recommendations are made for reducing this effect.

Introduction

Considerations of comfort, economy and health require the U value of the external walls of a building to be kept small. The upper limit depends on a number of factors, for example:

- the function of the wall (roof, façade, gable, etc.);
- the type of building (school, office, various categories of dwelling);
- geographical location of the building (climatic zone);
- the wall mass.

Tables published in C.S.T.B. Cahiers No. 34 and the building rules contained in R.E.E.F.-58^(2,3) give maximum recommended U values in each case.

Merely to follow these rules, however, is not enough to assure satisfactory hygrothermal behaviour of the wall. For this the ideal would be for the temperature to be the same at every point on the interior face of the wall. In the case of a homogeneous wall separating two spaces, an interior one of temperature T_1 and an outside one of temperature T_e , the temperature θ_1 on the interior surface of the wall once equilibrium has been established, is given by the equation

$$\theta_1 = T_1 - \frac{U}{h_1} (T_1 - T_e)$$

where U is the overall coefficient of heat transmission and h_1 is the inside surface conductance*.

The above equation shows that there are two causes of non-uniformity in the surface temperatures. First there is heterogeneity in the wall, producing different local U values. This is very frequent because materials with different thermal coefficients are increasingly being placed side by side in constructions, for example:

- a filling of hollow bricks next to a framing of reinforced concrete;
- a metal framing around a panel of a façade or its internal framing, next to the insulation which it encloses.

All those elements which have less insulating effect than the main part of the wall are weak points from the thermal point of view. They are commonly known as "thermal bridges".

The second cause is a variation of surface heat exchange resulting in a variation of the coefficient h_1 . These variations may be produced by a decrease in the exchanges due to radiation (on an aluminium moulding, for example) or convection (at corners, behind furniture).

Generally speaking the observed phenomena are the results of these various causes and it is impossible to determine the share of each.

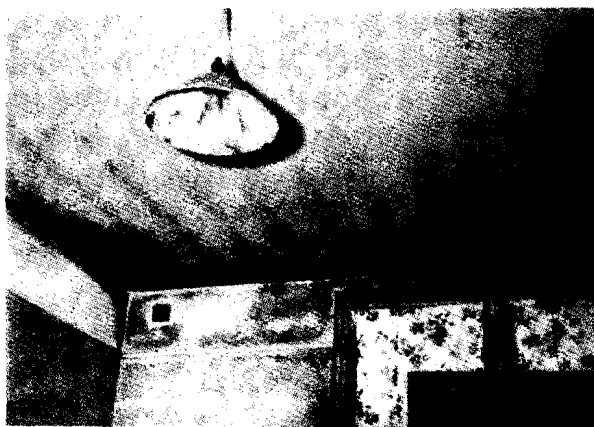

Traces of condensation on the ceiling of a basement apartment room
on cold spots produced by the tie beam and the
joists of the ground floor

The disadvantages of non-uniformity of surface temperatures are numerous.

In summer thermal bridges lead to warmer temperatures. In a temperate climate this is not very serious and the wall does not suffer from it. During cold weather, however, when the temperature of a thermal bridge is lower than

* The coefficient characterizes the thermal exchanges between the air and the surface of the wall. It depends to a small extent on surface condition and much more on the velocity of the air in contact with it.

the main part of the wall the situation is different. Several phenomena may then be observed



Condensation traces in the room of a ground floor apartment
at the gable end on cold spots produced by the corners
of the floors and the external walls

The main one is condensation of moisture from the room air on the surface of the wall. This will happen as soon as the dew-point of the humid air of the room is above the temperature of the thermal bridge surface. Condensation will occur first at this point and the amount of condensation will be greatest either during a period of high humidity or one of severe cold.

It is not our purpose here to study this phenomenon and its consequences in detail, but we wish to point out that a cold spot on the surface of a wall is its primary cause. The extent of condensation will depend, of course, on the conditions of occupation of the building (production of moisture, ventilation, heating, etc.) but before attempting to protect against the effects of this phenomenon it appeared necessary that the wall itself should be designed to prevent it by providing a sufficiently uniform temperature on the interior face.

Furthermore, in the absence of any humidity in the room, a cold spot gives rise to another phenomenon known as dust patterns. Even in rooms used as offices, where the atmosphere is always dry, the cold zones resulting from the beams, ties or even joints between masonry blocks eventually become

outlined by a considerable deposit of dust. This phenomenon can apparently be explained as follows:

The dust particles are kept in suspension in the air by molecular agitation and the shocks resulting from it. This agitation increases with increasing temperature. In the vicinity of a cold spot a disequilibrium occurs in the interaction, and the dust particles are thrown against the cold spot. Since the latter is generally moist as a result of even very slight condensation, the dust particles cling better to it.

Although this phenomenon is not as serious as condensation, it indicates that whatever the type of construction, a thermal bridge is always a defect.

The purpose of the present article is to report on the studies made by C.S.T.B. with a view to investigating practical methods of obtaining satisfactory uniformity of temperatures on interior surfaces.

Part I will be devoted to a qualitative study of the phenomena.

Part II will report on some artificial quantitative tests carried out on a number of special cases.

Part III will attempt to explain the results on the basis of a simplified theory. From this we shall be able to generalize in a number of simple cases.

Finally, in Part IV, drawing conclusions from our study, we shall give practical rules for estimating the effect of a thermal bridge and correcting it.

Part I

Qualitative Approach to the Problem by Semi-Natural Tests

Principle of semi-natural tests

The principle underlying these tests is as follows.

In a building, whose external walls are the walls to be studied, a warm and humid atmosphere is produced during the winter in the interior close to the inside surface of the wall. The external conditions are natural.

These tests were carried out only on walls of the reinforced concrete frame type filled with lightweight masonry.

To facilitate our study we have chosen for the filling cellular concrete of density 0.6 kg/dm^3 ($k = 0.3 \text{ kcal/mh}^\circ\text{C}$) which is decidedly more insulating than the mass concrete of the framework ($d = 2.2$; $k = 1.5$).

Three types of thermal weak points have been considered.

- total bridge, with framework traversing the wall completely;
- partial bridge with internal or external insulation;
- bridge and internal concrete slab diffusing the heat flux.

In the second case the width of the thermal bridge was varied as well as the thickness of the insulation.

These walls had an external coating of lime-cement mortar and an interior coating of plaster 1 cm thick. A reactive paint was applied over the plaster in order to emphasize the condensation and to permit a rough estimation of its extent.

Results

Figure 1 shows both the construction of the different bridges and the results obtained.

In the case of the total bridge, i.e. the framework traversing the entire thickness of the wall, whether this bridge was wide (vertical framing member in the centre of the figure) or narrow (horizontal frame member to the left) very considerable traces of condensation appear.

At the extreme left, on the thermal bridge with diffused heat flux the mildews are definitely less apparent.

At the right, on the various partial cold bridges with interior insulation, the traces of condensation are practically non-existent. No difference can be discerned between the wide and narrow ones on the one hand and the more or less insulated ones on the other.

However, to the left, on the two partial cold bridges with external insulation the condensation traces are very marked, practically similar to those obtained on the total cold bridges.

At first glance this appears to be a surprising result. Actually, the calculated thermal conductance of the wall at the thermal bridge is theoretically the same whether the insulation is placed inside or outside. Similarly the thermal bridge with diffused heat flux has the same U value as the total bridge.

In fact, these results show that the problem is much more complex, and that merely comparing wall U values at the thermal bridges with coefficients at right angles to the U values in the main part of the wall is by no means sufficient to solve it or even to predict the form that the phenomena will take.

It is because of these difficulties that we have undertaken much more precise artificial tests which will enable us to deal quantitatively with these phenomena.

Part II

Quantitative Study - Artificial Tests

Characteristics of a thermal bridge

The problems presented by thermal bridges can be reduced to the determination of the temperatures on the interior face of the heterogeneous wall

when the latter is situated in a cold external and warm internal environment. The curve giving the temperature distribution on the internal surface, as shown for example in Fig. 2, then enables us to characterize the thermal bridge. Two elements must be considered, first the spreading out of the curve which enables us to determine the width of the zone where condensation is to be feared, and second the temperature of the coldest spot. The absolute value of this temperature is not so important because it depends essentially on the interior and exterior temperatures. We therefore introduce a coefficient which characterizes the heterogeneity of interior surface temperature:

$$\rho = \frac{T_1 - \theta}{T_1 - \theta_c}$$

where T_1 is the interior air temperature, θ the interior surface temperature of a point in the thermal bridge zone and, θ_c the interior surface temperature at a point remote from the thermal bridge in the main part of the wall.

In Part III it will be shown that this ratio is practically independent of the interior and exterior temperatures. Denoting the maximum value of ρ by ρ_m , then

$$\rho_m = \frac{T_1 - \theta_m}{T_1 - \theta_c},$$

where θ_m is the temperature of the coldest point on the thermal bridge.

This coefficient, which we shall call the coefficient of interior surface temperature heterogeneity indicates to a certain extent by how much the coldest point is colder in relation to the internal air temperature than the main part of the wall.

We shall wish to compare this coefficient to the coefficient ρ_c (theoretical calculated coefficient) which is determined from the wall U value at the thermal bridge (U_p) and the wall U value away from the thermal bridge* (U_c) as follows:

$$\rho_c = \frac{U_p}{U_c}.$$

Test method

Exact determination of the curve of ρ values by calculation is impracticable.

* Translator's note: There is no exact rendering for "la partie courante du mur". It means basically any part of the wall not close to the edges.

The method of direct observation is delicate, because the measurement of a surface temperature is difficult to carry out with precision. However, it is the only way in which the various factors which may influence ρ can be taken into account.

The tests were carried out in the thermal room of the Champs-sur-Marne experimental station⁽¹⁾ (Fig. 3).

The wall containing the thermal bridges to be studied divided the room into two spaces. The interior warm space was kept at a controlled temperature of approximately 30°C while the exterior cold space was kept at about -5°C. The interior temperature was placed intentionally higher than average room temperature in order to increase the difference between the two environments, thereby enhancing the accuracy of the measured interior surface temperature. This will not affect the results because the values of ρ are practically independent of temperature. Air temperatures were recorded continuously during the test by means of resistance thermometers connected to a recording potentiometer. Furthermore, since the purpose of the study was to eliminate condensation, matters were arranged so that the thermal characteristics of the materials and their temperature would not be affected by condensation. The atmosphere of the interior room was dry (approximately 35% relative humidity) so that no condensation would take place on the cold spots.

The wall surface temperatures were measured with iron-constantan thermocouples 1/10 mm in diameter. These thermocouples were connected to a 12-point recording potentiometer. Temperatures were thus recorded simultaneously at 12 points on the zone in question. We thus obtained an accurate summary of the surface temperature curve (Fig. 2).

Note I:

We wish to recall one of the characteristics of the room which is essential to the study. This has to do with the surface heat exchanges between the air and the wall. A certain number of measurements carried out on homogeneous walls have shown that the convection conditions created in the two rooms, for walls with U values of approximately 1.2 kcal/(m²h°C), gave surface conductances of approximately 7 kcal/(m²h°C) for the interior environment and 18 kcal/(m²h°C) for the exterior. It was very important that the inside surface heat exchanges during the tests were similar to practical surface heat for the test wall or at least to theoretically determined value (i.e. $h_1 = 7$ kcal/(m²h°C). It may then be assumed that surface temperature variations will be due to wall thermal properties.

Note II

Some investigators have taken advantage of the similarity between the equations of electrical transmission and those of heat transmission in order to construct electric models of walls⁽⁹⁾. Thus a continuous model can be obtained with electrolytes. The determination of temperatures is then replaced by a determination of voltage, which is much more accurate.

However, these provide only approximate solutions, for the following two reasons:

Surface conductance, which is represented by fixed resistances in such a model, is a function of the temperature difference between the environment and the wall, thus of what we are trying to determine. A method involving successive approximations should enable us to take the variation of surface conductance into account. Accuracy may be decreased, however, since the way in which surface conductance varies with temperature is not very well known.

The second reason is much more serious, because there is no simple way of avoiding it. This has to do with the fact that heat exchange between two materials in contact is dependent not only on their conductivity coefficient but also on their specific heat and density. Electrical analogy methods cannot reproduce conductivity ratios and do not take into account thermal capacity.

Choice of types of thermal bridges

The test method used is not very quick. It is necessary to wait for the establishment of steady state heat flow conditions for each wall. This may take ten or more hours for light panels and as much as forty-eight hours for heavy masonry walls.

Once steady state has been established with the thermocouples in place from the beginning of the test, air and surface temperatures can be recorded in fifteen minutes. The actual measuring time is thus very small compared with the time required to reach steady state. As a result several test models, generally four, are grouped in a single wall. Only the most characteristic types are studied.

Our choice was guided by one prime consideration. We classified the walls in three categories according to the thermal characteristics of the materials from which they are made:

First we have pure masonry walls, in which reinforced concrete is next to light masonry (hollow brick, artificial stone, light-weight concrete, etc.). These walls may be constructed in the traditional manner or may consist of large prefabricated panels containing these elements. The thickness of these walls varies between 20 and 30 cm, the ratio of densities of the materials

present is between 2 and 4 and that of the thermal conductivities between 3 and 5.

Next, we have mixed walls in which reinforced concrete and very light insulating materials are used side by side; these are generally large prefabricated panels. They have about the same thickness as the above walls, but the ratio of densities of the materials varies between 20 and 100 and the ratio of conductivities between 30 and 50.

Finally, we have light walls, of thickness between 3 and 5 cm, which consist of very light insulating materials standing next to wood or metals.

The characteristics of the materials constituting the different types of walls are summarized in the following table:

Types of wall		Density in kg/m^3	Conductivity k in $\text{kcal}/(\text{mh}^\circ\text{C})$
Heavy walls	Reinforced CONCRETE frame and ..	2200	1.5
	LIGHT WEIGHT MASONRY filling ...	600 to 1000	0.3 to 0.6
Heavy walls	Large prefabricated concrete ...	2200	1.5
	panel incorporating very light INSULATION	20 to 100	0.03 to 0.05
Light walls	Curtain or panel façade walls with a framing of WOOD	400 to 700	0.1 to 0.15
	or METAL	3000 to 8000	50 to 170
	and very light INSULATION	20 to 100	0.03 to 0.05

Heavy walls

Reinforced concrete framework with light-weight masonry filling or large, light-weight masonry panels

We have adopted the same types of thermal bridges that had been studied previously in the semi-natural tests. For convenience the models consisted of blocks of cellular concrete ($d = 600 \text{ kg/m}^3$, $k = 0.3$) interrupted by a dense concrete framing ($d = 2,200$, $k = 1.5$).

Total bridge. In addition to the total thermal bridge (Fig. 4, models A₁ and A₂) for which we took the same two widths as studied in the semi-natural tests, namely 7.5 and 22.5 cm, we studied various arrangements in which, a priori, it was possible to obtain more uniform interior surface temperatures.

The different arrangements studied can be reduced to two.

First arrangement: Thermal bridge with interior diffusion layer (Fig. 5).

One solution consists in diffusing the surface temperatures by placing a comparatively conductive material over the entire interior surface of the wall.

The effectiveness of this method had been demonstrated in the semi-natural tests. In the artificial tests we attempted to calculate it.

Starting with a bridge comprising a framework of compact concrete intersecting a cellular concrete block wall 20 cm thick, we studied the effect of a compact slab of concrete 5 cm in thickness (B_1) for frame widths of 7.5 and 22.5 cm. We thought it would be interesting to increase the conductivity of this slab in the lateral direction, perpendicular to the framing. For this purpose, additional slabs, identical to the preceding ones except that they were strongly reinforced with iron rods running perpendicular to the framework (B_4), were applied to the interior surface.

Similarly, we tried to increase the effectiveness of a plaster coating (of relatively low conductivity) by reinforcing it strongly with two layers of grillwork (B_5).

Still other specimens were constructed to determine the effect of various degrees of flaring of the framework.

Finally we sought to determine the effect of a framing which by projecting greatly on the exterior forms a cordon, and hence a kind of cooling fin, by increasing the area of the exterior surface.

Second arrangement: Insulation of thermal bridge.

Two solutions have been studied:

(1) Partial bridges (Fig. 6). In this solution the framing does not go all the way through the wall and is thus insulated by a certain thickness of the material* which constitutes the main part of the wall.

The semi-natural tests demonstrated that there was a great difference in effectiveness depending on whether the insulation was placed inside or outside. With a view to determining these effects more accurately we studied the same types of thermal bridges in the artificial tests.

For this purpose a cellular concrete wall 20 cm thick was constructed. This wall was partially intersected by two dense concrete frameworks, one 7.5 cm wide and the other 22.5 cm wide. The residual thickness of the cellular concrete was 5 cm and 7.5 cm, respectively. Four specimens were thus available. This wall was tested on both sides so that the insulation could be placed successively on the inside and on the outside.

(2) Corrected bridges (Fig. 7). This term refers to a bridge insulated by very effective insulating material, the thickness of which was calculated so that the U value at right angles to the insulated framework would be equal to that calculated for the main part of the wall. (We then have $\rho_c = 1$.) We

* See translator's note, p.10.

again took the case of wall A, where the thermal bridge consisted of a dense concrete framework intersecting a 20 cm thick wall of cellular concrete covered by a plaster coating 2.5 cm thick. In the first test the plaster was removed opposite the frames which were 7.5 and 22.5 cm wide, and replaced with 2 cm of aerated polystyrene.

One test was carried out with polystyrene on the interior and one with polystyrene on the exterior.

The 2 cm thickness was chosen in such a way that $U_p = U_c$, i.e. $\rho_c = 1$.
Large concrete panel with very light insulating materials incorporated in it

In general, these panels are built in sandwich fashion; a very good insulating material, which provides good thermal insulation, is sandwiched between two concrete slabs of various thicknesses which perform the other functions of the wall (mechanical strength, permeability, thermal inertia, etc.).

Very frequently, then, thermal bridges are formed by the concrete joining strips between the outer and inner slabs or by the joints between two panels. The difference between the conductivities and specific gravities of the different materials involved ($k = 1.5 \text{ kcal}/(\text{mh}^\circ\text{C})$; $d = 2,200 \text{ kg}/\text{m}^3$ for the concrete and $k = 0.03$ to 0.05 ; $d = 20$ to 100 for the insulation) results in very substantial thermal bridges.

In this case we tried to determine precisely the respective role of the two concrete slabs, especially that of the interior one.

The walls studied had the following thicknesses:

A concrete slab of 5 cm; a slab of polystyrene 3 cm thick (giving a useful thickness of about 2.5 cm, since the concrete penetrated slightly into the polystyrene on both its faces); and a concrete slab 15 cm thick. Openings 7.5 cm, 15 cm, 22.5 cm and 45 cm wide were provided in the polystyrene, thus constituting a link between the two slabs, and a thermal bridge.

These walls were tested with the 5 cm slab and the 15 cm slab successively on the warm side.

Special thermal bridges

We also initiated a study of thermal bridges existing at corners. The study is even more complex, because it is necessary to distinguish between the corner where two identical external walls join (Fig. 8) and the corner where an external wall is joined by a partition or floor (Fig. 9).

Thermal bridges at the corner between two external walls. In this case, even with two walls having the same U value, the temperatures at the corner will be different from the temperatures elsewhere on the walls. There are two reasons for this:

First the surface area of the external wall is greater than that of the internal wall. The same flow of cold from the exterior will thus lead to

lower temperatures than on a wall with parallel faces.

Then, there is a reduction in the radiation and convection surface heat exchanges. This further contributes to the lowering of the temperature on the inside surface.

Artificial tests on this type of thermal bridge are rather uncertain and it is doubtful whether or not the surface heat exchanges can be exactly reproduced. On the other hand, we possess the results of natural tests carried out in Germany at the Holzkirchen Station⁽⁷⁾, where temperatures were measured on the interior surface of the northwest corner of more than 20 houses with different kinds of walls.

Partitions and floors. Where an external wall meets a partition or floor the problem is very different. The partition or floor is at the interior room temperature (we assume that the wall or floor separates two equally heated spaces). The exterior surface area is not as large as the interior surface area. Thus the two effects mentioned previously oppose one another. Furthermore, the partition or floor often differs greatly in its thermal characteristics from the exterior wall.

Finally, both partitions and floors can terminate flush with the façade, or before reaching the façade, or can even extend beyond it, forming a cordon. Only the corner between the exterior wall and the partition has been studied. For this purpose a structure representing the partition was joined at right angles to the 22.5 cm wide frames of walls A, B and C. This structure was constructed from solid blocks identical with the concrete of the frame.

In the case of wall B we also studied the influence of an exterior structure forming a cordon and cooling fin.

Light walls (curtain walls, façade panels)

One of the essential features of this kind of construction is the very small thickness of the wall which is made possible by the use of good insulation: the same U value can be obtained with a wall using a 2 cm thickness of good insulation ($k = 0.03$ to 0.05) as with one 20 cm thick in light masonry.

In order to compensate for their lack of thermal capacity these walls must have very good U values (around 1.0). Such coefficients are easily obtained with small thicknesses of insulating material.

When this insulation is interrupted by a frame which is also very thin, significant thermal bridges are formed.

We shall distinguish between thermal bridges produced by wooden members which generally make up the internal framing of panels and those produced by metal frames, whether they are internal frames, as are frequently used in this type of construction to ensure rigidity and ease of assembly, or are external frames in which the homogeneous panel is placed.

Wooden or similar framing

Total bridge. The main part of the models was constructed of 3 cm thick expanded polystyrene ($k = 0.03 \text{ kcal}/(\text{mh}^\circ\text{C})$; $d = 20 \text{ kg}/\text{m}^3$).

We studied the effect of the width of the frame. For this purpose the insulation was interrupted by members having the same thickness as the panel (3 cm) but of different widths (0.6, 1, 3 and 6 cm).

In order to estimate the effect of changing the ratio of thermal characteristics of the materials, models identical with the above were built, but in which the wood was replaced by pressed wood that was more insulating and lighter ($k = 0.06$ and $d = 500 \text{ kg}/\text{m}^3$) than the wood used in the previous test.

Bridge with interior diffusion layer. We again wished to determine the effect of a conducting layer on the interior surface. Some panels use aluminium foil under the interior layer as vapour barriers. It is quite possible that this highly conductive material significantly diffuses the temperatures despite the small thicknesses employed. In order to calculate this phenomenon we cemented first a sheet of aluminium 1/10 mm thick on to the models ($k = 170 \text{ kcal}/\text{mh}^\circ\text{C}$) and then a sheet of copper 2/10 mm thick ($k = 350 \text{ kcal}/\text{mh}^\circ\text{C}$).

These sheets had been painted grey to maintain the same surface heat exchange as before.

Metal framing

Total bridge. To begin with we studied total bridges formed with various steel sections intersecting a polystyrene panel 3 cm thick.

We then sought to determine the influence of increasing or decreasing the projection of an exterior cordon constituting a cooling fin.

Interrupted bridge. Seeking a remedy to this type of thermal bridge we studied, for a simple theoretical case, the effect of an interruption in the thermal bridge, or more exactly a decrease in the metal cross-sectional area and an increase in the thermal path length.

Practical examples. Finally, we studied some practical examples of thermal bridges at the joint between two panels. Again, seeking to correct the thermal bridge, we studied the effect of interrupting the framing and its insulation with various types of interior and exterior mouldings.

Results

Heavy walls

Walls with reinforced concrete framing and light masonry filling

The results obtained are shown in Table I, where we give the values of ρ_m determined from the measured temperatures and those of ρ_c calculated from the ratio U_p/U_c .

Total bridge. Actually a true total bridge was not tested since no such bridge exists in practice. There are always interior and exterior coatings. The first tests carried out on walls A ($A_1 - A_2$) enabled us to obtain the real value of the total bridge in a wall with coatings and we found that:

$$\rho_m = 2.1 \text{ for the } 7.5 \text{ cm width;}$$

$$\rho_m = 2.3 \text{ for the } 22.5 \text{ cm width.}$$

We note that the narrower the framing the smaller ρ_m , and that in both cases it is less than ρ_c : $\rho_c = 2.4$.

Thermal bridge with interior diffusion layer. The effect of the concrete slab placed on the interior surface is to flatten the curve of interior surface temperatures. The important improvement obtained with a simple slab (B_1) must be noted:

$$\rho_m \text{ changes from } 2.1 \text{ to } 1.4 \text{ for the } 7.5 \text{ cm width;}$$

$$\text{and from } 2.3 \text{ to } 1.7 \text{ for the } 22.5 \text{ cm width.}$$

These values are far less than ρ_c , which is still equal to 2.4:

- The flaring of the framework ($B_2 - B_3$) makes it possible to obtain still smaller ρ_m values. In this way we achieved values of 1.3 for $l = 7.5$, and 1.45 for $l = 22.5$;
- Putting reinforcement (B_4) in the slab makes very little difference. Depending on the width, ρ_m changes from 1.4 to 1.35 and from 1.7 to 1.65.

We also tested the effect of reinforcement in the plaster slab installed in such a way as to make the relatively insulating plaster more conductive in the lateral direction. Again (B_5) the results were inconclusive; ρ_m changes, depending on the width, from 1.95 to 1.9 and from 2.2 to 2.15. The effect is thus negligible.

Generally speaking ρ_m decreases as l decreases and it is always less ρ_c .

Note. The effect of an exterior fin (B) is also comparatively slight in this case; it causes ρ_m to change from 1.7 to 1.8 (B compared to B_1).

Partial bridges. The reader will note the large difference in the shape of the curves obtained when the insulation is on the inside (C_1 and C_2) and when it is on the outside (C_3 and C_4).

(a) In the case of interior insulation a very good correction of the thermal bridge is obtained, and the narrower the frame to be protected, the better the correction. The coldest point is directly opposite the centre of the frame. The small difference obtained with different thicknesses of insulation should be noted (C_1 compared to C_2).

Note again that $\rho_m < \rho_c$.

(b) When the insulation is placed on the exterior there is no improvement and now it seems as though the smaller the width of the frame, the more pronounced is the effect of the thermal bridge. The thickness of the insulation is more significant.

We again note that the position of the coldest point is situated opposite to the frame, but near the edge. Note also the existence of a warm spot near the frame. The temperature there is higher than in the main part of the wall.

Finally it must be emphasized that ρ_m is decidedly greater than ρ_c . It is thus an error to suppose that the classical calculation always yields a margin of safety. These results are absolutely opposite to those obtained for interior insulation.

We shall explain this in Part III.

Corrected bridges. (a) The above results, in the case of exterior insulation, are rather surprising; the tests carried out on wall D with exterior correction have confirmed them. Although conditions were chosen so that the U value of the wall at the frame would be the same as in the main part of the wall ($\rho_c = 1$), very different temperatures are observed on the interior surface.

In particular, for the 7.5 cm width replacing the exterior plaster coating with 2 cm of polystyrene has practically no effect on the temperatures and gives substantially the same value for ρ_m .

An improvement of the thermal bridge can be obtained by having the insulation overlap the frame considerably on both sides, but the results remain unspectacular. For a narrow bridge an overlapping on both sides of 7.5 cm equal to l still gives a high ρ_m value (1.65). For a wider bridge an overlapping on both sides of 22.5 cm (equal to l) gives $\rho_m = 1.5$.

(b) In the case of interior correction, the temperature opposite the frame is higher than on the main part of the wall; the coldest spot, however, is displaced outside the frame. The wider the frame, the colder this spot will be.

In tests D₄, where the insulation overlaps the frame, good improvement can be observed. However, it does not appear that the width of the insulation required to obtain a given ρ_m is a linear function of the width of the frame. An overlapping of 7.5 cm for a frame width of 7.5 cm is sufficient ($\rho_m = 1.25$), while an overlapping of 22.5 cm for a 22.5 wide frame is excessive ($\rho_m = 0.87$).

Finally, we note the difference of form in the temperature curves obtained between the case where the insulation is inside, and that where it is outside. To show this result more clearly we have plotted the values of ρ for both of these cases on the same graph (Fig. 10) - tests D₁ and D₃. Although the ρ_m values are not very different the curve of ρ for interior insulation is

much less flat in the zone of $\rho > 1.5$ than the curve obtained for exterior insulation.

Large concrete panel incorporating light insulation

The results are given in Table II.

The very high value of ρ_m obtained when the framing is very wide ($\rho_m = 3.2$) should be noted.

With the 15 cm slab on the inside, the best correction is obtained with the narrow thermal bridge. A width of 7.5 cm still gives a high ρ_m value (1.8).

With the 15 cm slab on the outside, the values of ρ_m remain very high (above 3). For the larger bridge widths (15 and 22.5 cm) they are slightly above ρ_c ($\rho_c = 3.4$).

Special thermal bridges

Partitions and floors. Table III shows the results obtained in the four cases studied.

The coldest point is found on the partition a few centimetres away from the corner.

In the last column of Table III are given values of ρ_m obtained on thermal bridges at walls without partitions. Those obtained with partitions are always lower. This is due to the fact that the concrete partition, away from the corner, is at temperature T_1 through its entire mass so that there is a considerable flow of heat in the direction of the corner.

The total bridge (A) now gives a ρ_m value of only 1.9 instead of 2.4.

We again find that good diffusion is obtained with the internal concrete slab, enabling the attainment of $\rho_m = 1.5$ without a cordon and $\rho_m = 1.55$ despite a large cordon. External insulation continues to be ineffective ($\rho_m = 1.7$).

Corner between two outside walls. At a corner between two external walls values of ρ_m , which can be derived from German tests⁽⁷⁾ are higher. For walls with U values of 1.2 to 1.5 they are in the vicinity of 1.8, while for walls with U values of less than 1 they reach 2.5.

The shape of the curve is then different.

Figure 12 shows the temperatures obtained at the corner between the west and north walls, which were solid brick 38 cm thick. The curve shows a sharp peak; the result is a colder but less extensive area. Thus the effect of the maximum ρ_m which is obtained can be less severe.

Light walls (curtain walls, façade panels)

Wooden framing

Total bridge. The results are given in Table IV. The narrower the framing, the smaller the ρ_m values. They are always smaller than ρ_c , which for

wood is equal to 2.8 and for pressed wood 1.7.

For wooden framing the surface temperature curve shows a rather sharp drop at the edges of the framing.

In the case of pressed wood framing, however, the curve is flatter.

Thermal bridge with interior diffusion layer. The technical difficulty of obtaining a perfect thermal contact between the metal foil and the wall without an intervening cushion of air made it impossible to determine accurately the effectiveness of diffusing the heat flux. On the other hand, foils are generally put underneath the interior plaster, which adds an effect of its own. Our tests indicate, however, that for the wooden framing it seems possible to diffuse the heat flux sufficiently in this way in order to obtain acceptable surface temperatures. Thus it should be possible to obtain $\rho_m = 1.5$ with a 1/10 mm aluminium foil under a covering of plaster board or plywood on a wooden framework less than 2 cm wide for the hardwood (oak) used in the tests, or 3 cm for soft wood (fir).

Metal frameworks

Theoretical cases. The main part of the wall consisted of 3 cm expanded polystyrene framed with steel sections of various shapes.

The tests showed that the temperature on the metal part was practically uniform, with a sudden drop occurring at the edge of the section (Fig. 13).

The results are collected in Table V. We have included at the same time values of $\rho_m = \frac{T_1 - \theta_m}{T_1 - \theta_c}$ and of $\mu = \frac{T_1 - \theta_m}{T_1 - T_e}$. In part three it will be shown that for this case θ_m is practically independent of θ_c , so that the ratio μ will remain essentially constant regardless of the U value of the main part of the wall. This is why μ is of interest here.

This ratio establishes the surface temperature of the framework in relation to the internal and external temperatures.

Thus $\mu = 0.5$ indicates that the surface temperature on a framework is the arithmetic mean of T_1 and T_e .

If $\mu < 0.5$, this temperature is closer to T_1 than T_e ; if $\mu > 0.5$, it is closer to T_e than T_1 .

Two types of thermal bridges may be distinguished.

(1) Total bridge (top of Table V). The smallest value of μ is obtained for the T-section with the flange on the interior. What we get, in effect, is a diffusion by the flange. If the flange were wider the value of μ would certainly be smaller.

When the flange of the T is to the outside the situation is reversed, with the result that $\mu = 0.8$. The wider the flange, the greater this effect would be. The I-section gives a μ which is practically an average of the two preceding ones.

(2) Thermal bridge with fin (centre of Table V). The values of μ is decidedly higher, corresponding to a lower temperature than for the same test without a fin. The larger the fin the more pronounced this effect.

(3) Interrupted thermal bridge (bottom of Table V). Decreasing the area of metallic section between the two iron plates helps to decrease the value of μ . The curve of Fig. 16 shows that in the last test, which corresponds to an area of 1 cm per m of section the ratio μ has practically attained its limiting value, given by the heat exchange through the layer of air between the two iron plates. However, a layer of air in this kind of panel is itself a thermal bridge. In order to obtain a satisfactory effect the joining member between the two plates should pass through the insulation.

Practical Examples. The results obtained in the following three examples have confirmed and supplemented the results previously obtained in the theoretical cases.

(1) Example of a total bridge with fin. We first studied the thermal bridge produced by a large metal framework containing homogeneous panels. The panel had a U value of approximately 1 kcal/m²h°C. The framing, which projected considerably on the outside, forms a definite cooling fin. Figure 17 shows a plan section of the framing and the temperature curve obtained. From this we calculate

$$\rho_m = 5.7$$

$$\text{and } \mu = 0.75,$$

very high values from which we may deduce that for $T_1 = 18^\circ\text{C}$ and $T_e = -6^\circ\text{C}$ the temperature on the framing will be 0°C .

This very high μ value is due largely to the fin, but probably also to an appreciable decrease in the radiation exchange between the metal surface and the interior.

(2) Examples of improvement of a total bridge by interruption and by interior mouldings.

Another, more classical example is the façade panel bounded by an omega-shaped frame (Fig. 18).

The test panel had a U value of approximately 0.9 kcal/(m²h°C).

Several tests have been carried out on the joint between two panels. First the thickness of the framing head was varied; then an attempt was made to reduce the heat flow area by providing holes or slots and to lengthen the thermal path or to interrupt the thermal bridge in one way or another.

Finally the effect of an internal moulding either of wood or polystyrene (which insulated the interior side of the thermal bridge) was studied.

The results are shown in the curves of Fig. 18.

(a) Interrupted thermal bridge

The circular perforations are relatively ineffective since the reduction in heat flow area and the increase in path length is slight.

On the other hand three rows of slots in staggered array reduce ρ_m from 4 to 2.7, which, however, is still a very high value.

(b) Interior moulding

The application of a moulding has the effect of moving the coldest spot to the edge. The result is the same as for the case of the thermal bridge corrected by an interior insulation. It is important to note that the diffusions obtained with the wooden moulding is better than that obtained with the expanded polystyrene moulding. The latter slightly decreases the temperature variation opposite the frame, but the variation is increased at the edge of the moulding. The width of the moulding seems to be more important than its insulating power. To obtain satisfactory results it should be quite wide.

(3) Example of improvement by an exterior moulding.

In the third example exterior insulation was the chief subject of investigation. The panel was again bounded by a metal frame of a rather elaborate form shown diagrammatically in Fig. 19. The main part of the panel had a U value of 1 kcal/(m²h°C).

The joint between the two panels was covered with an exterior steel moulding and an interior plastic moulding.

We decided to test this joint, as just described, after filling the space between the exterior moulding and the panels with glass wool, and finally with an additional filling of light insulation between the exterior moulding and the panels.

The results obtained are shown in Fig. 19. Again we find the relative ineffectiveness of exterior insulation and of too narrow an interior moulding.

References

- FRANCE**
1. « La Chambre thermique de la Station expérimentale de Champs-sur-Marne », *Cahier du C.S.T.B.*, n° 24-25 (fascicule 216).
 2. « Recommandations pour l'emploi des maçonneries légères en considération de leurs caractéristiques thermiques utiles », *Cahier du C.S.T.B.*, n° 34 (fascicule 277).
 3. *R.E.E.F.*-58 (tome I, page 603).
 4. *Manuel des Industries Thermiques* (tome I).
- CANADA**
5. G. O. HANDEGORD « Wall Surface Temperatures », *ASHAE Journal Section Heating Piping and air Conditioning* (juin 1957).
- ENGLAND**
6. N. S. BILLINGTON « Thermal properties of Building ».
- Publications de l'Institut technique de Stuttgart.*
- GERMANY**
7. M. REIHER, D. V. SODEM, H. KUNZEL « Wärme-und Feuchtigkeitsschutz in Wohnbauten » (1958).
 8. *Cahier 29* (1954). W. SCHÜLE, H. SCHÄCKE « Wärmebrücken im Wohnungsbau » (1).
 9. *Cahier 29* (1954). W. SCHÜLE, H. KUNZEL « Modelluntersuchungen über die Wirkung von Wärmebrücken in Wänden » (1).

Table I

Heavy walls: Reinforced concrete frame - Light masonry filling
or large panel of light masonry

TOTAL BRIDGES

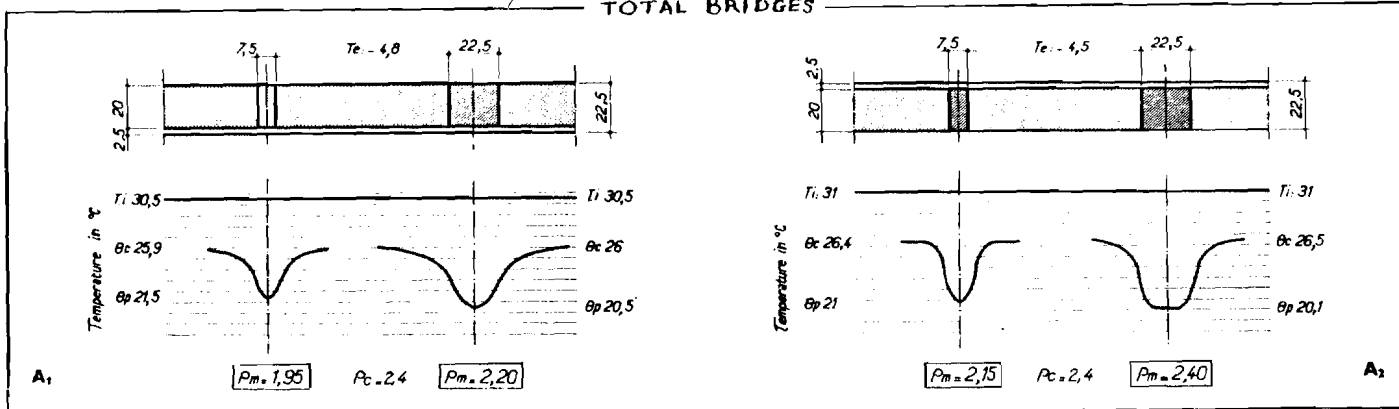

BRIDGES WITH INTERIOR DIFFUSION LAYER

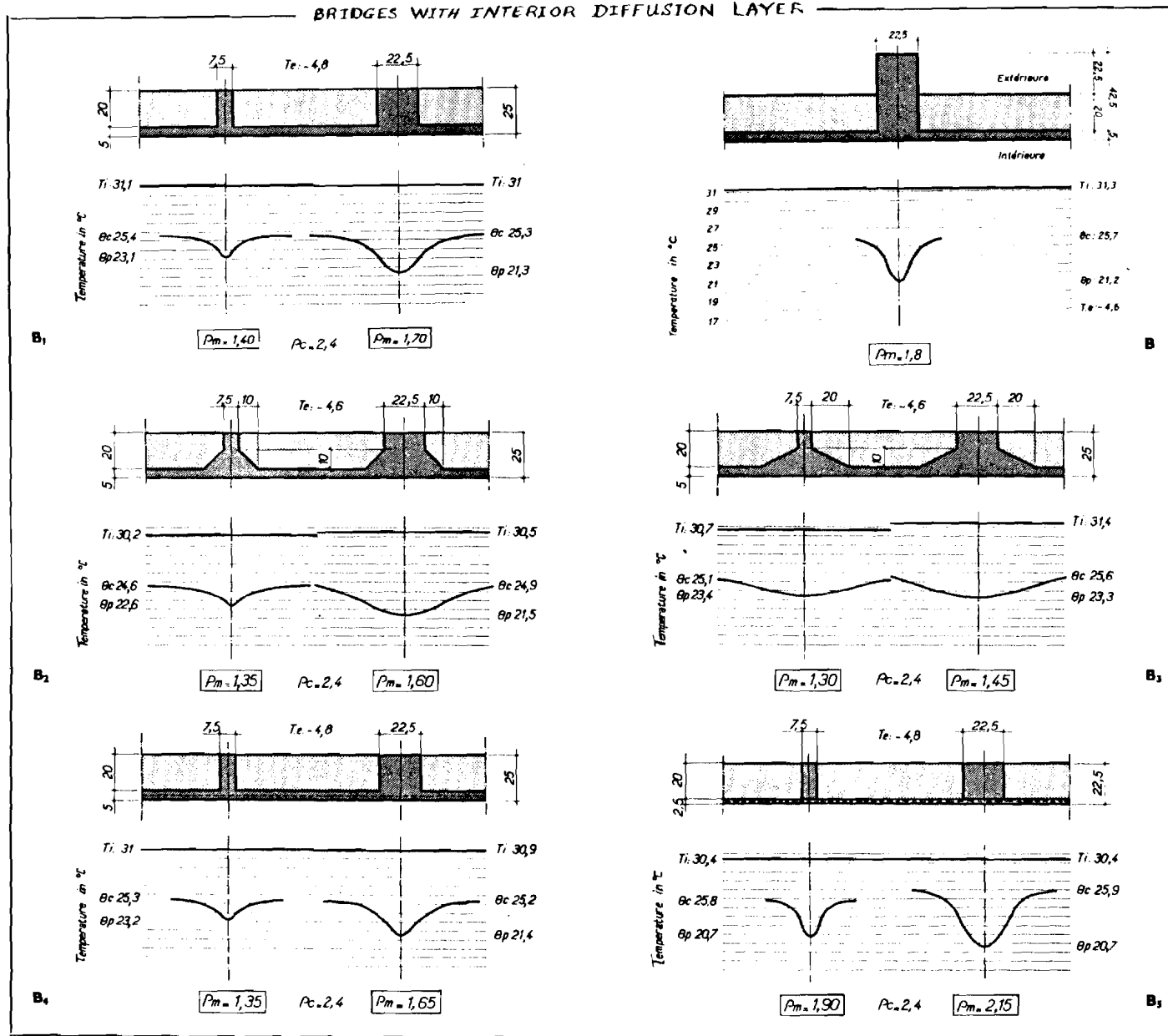

Dense concrete
 Cellular concrete
 Reinforcement
 Plaster
 Expanded polystyrene

continued

Table I - continued

PARTIAL BRIDGES

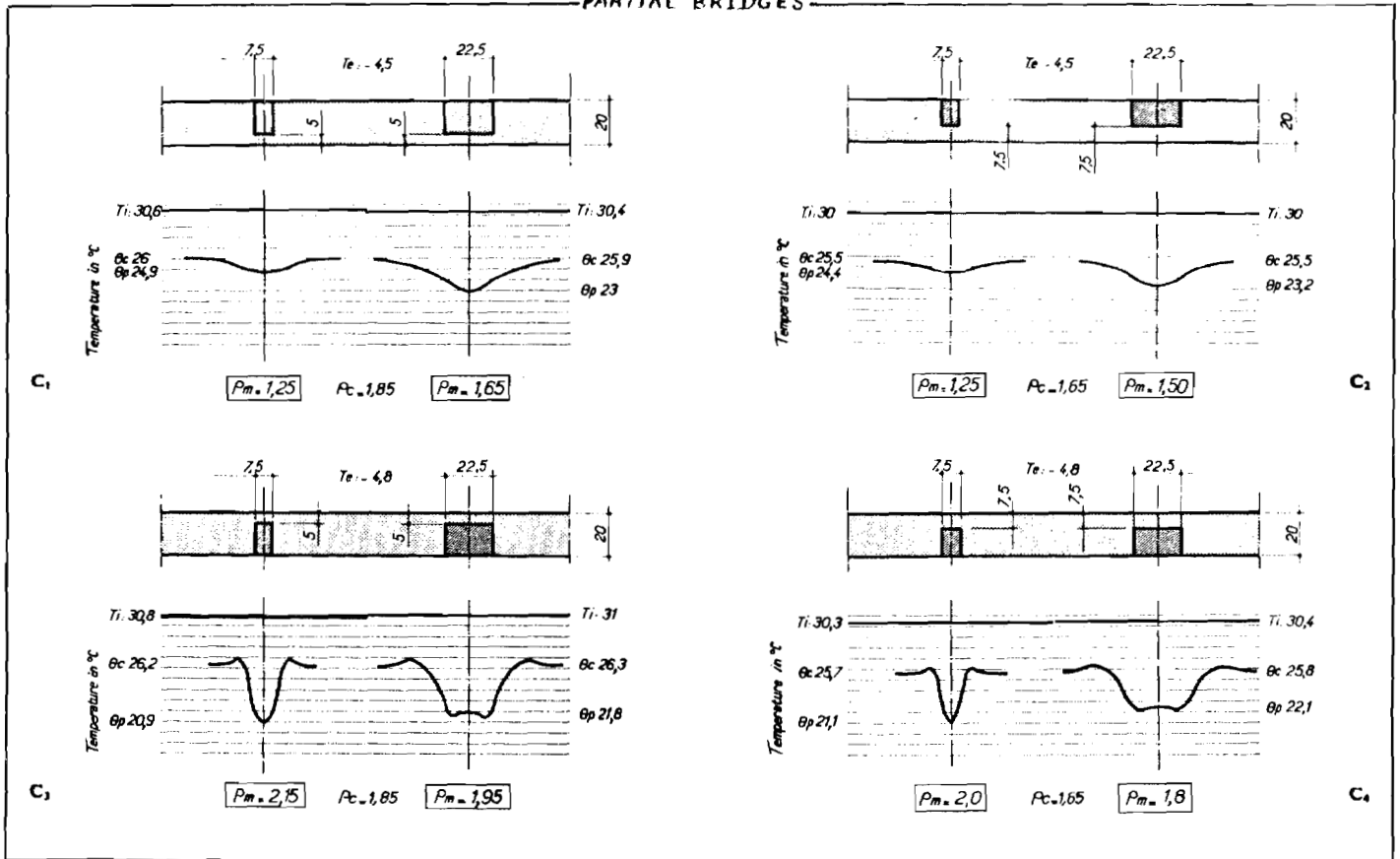

CORRECTED BRIDGES

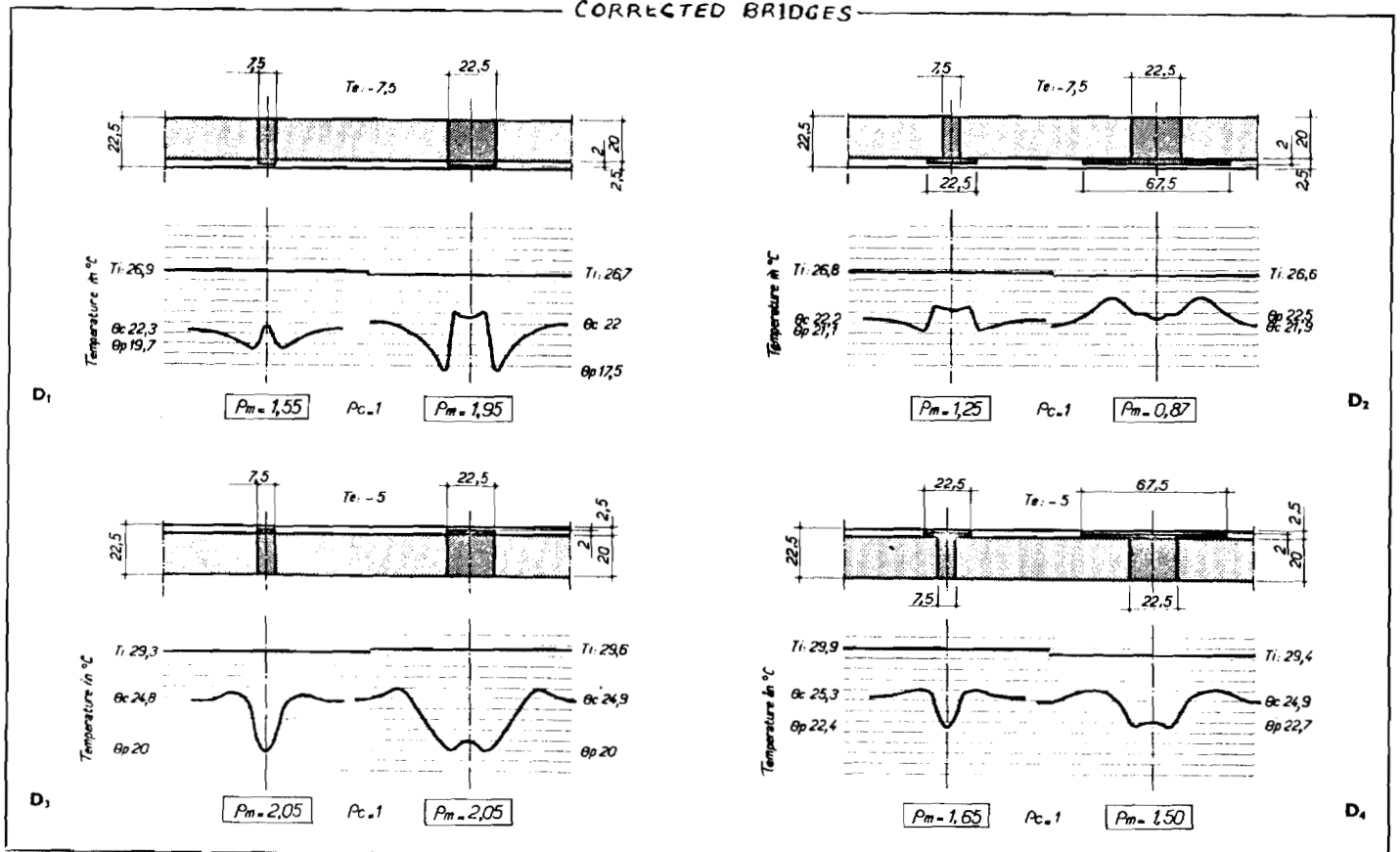
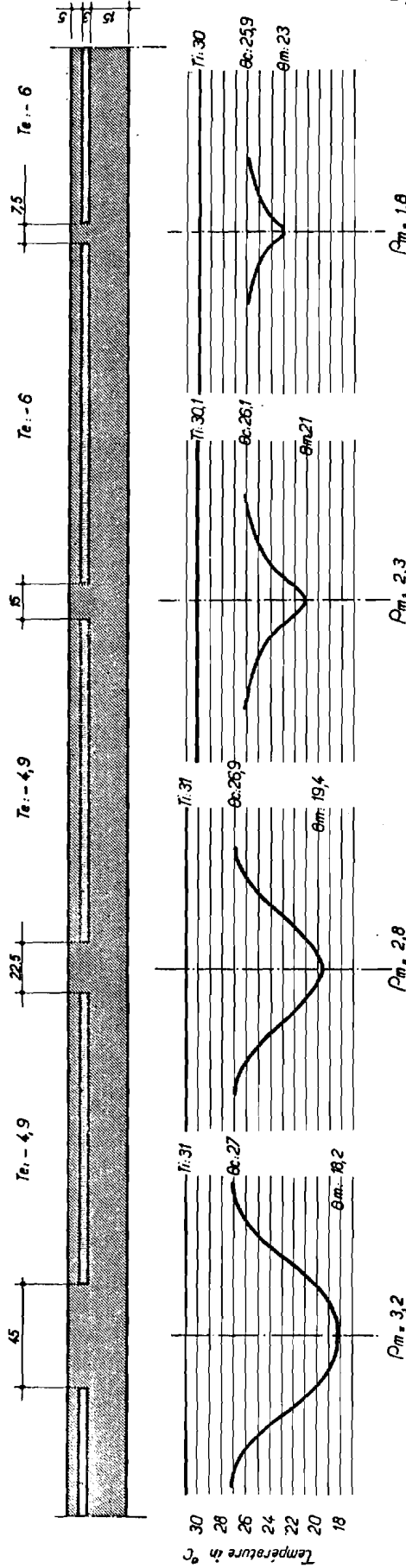
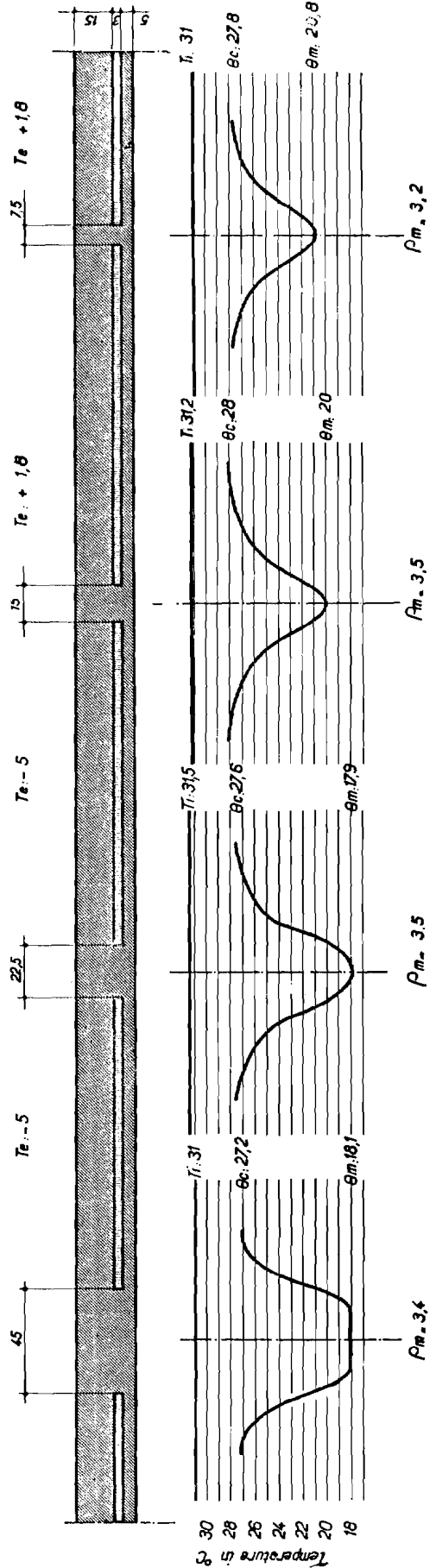

Table II

Large concrete panels incorporating light insulation



Thick interior slab : $\rho_c = 3.4$.



Thick exterior slab : $\rho_c = 3.4$.

Table III

Special thermal bridges - Partition

	Diagram of models	Temperature curves	P_m	P_m of wall without partition
TOTAL BRIDGE			1,9	2,4
BRIDGE WITH INTERIOR DIFFUSION SLAB			1,5	1,7
BRIDGE WITH INTERIOR DIFFUSION SLAB AND CORDON			1,55	1,8
PARTIAL BRIDGE			1,7	1,95

Table IV

Light walls: Total bridges with wooden frame and pressed wood frame

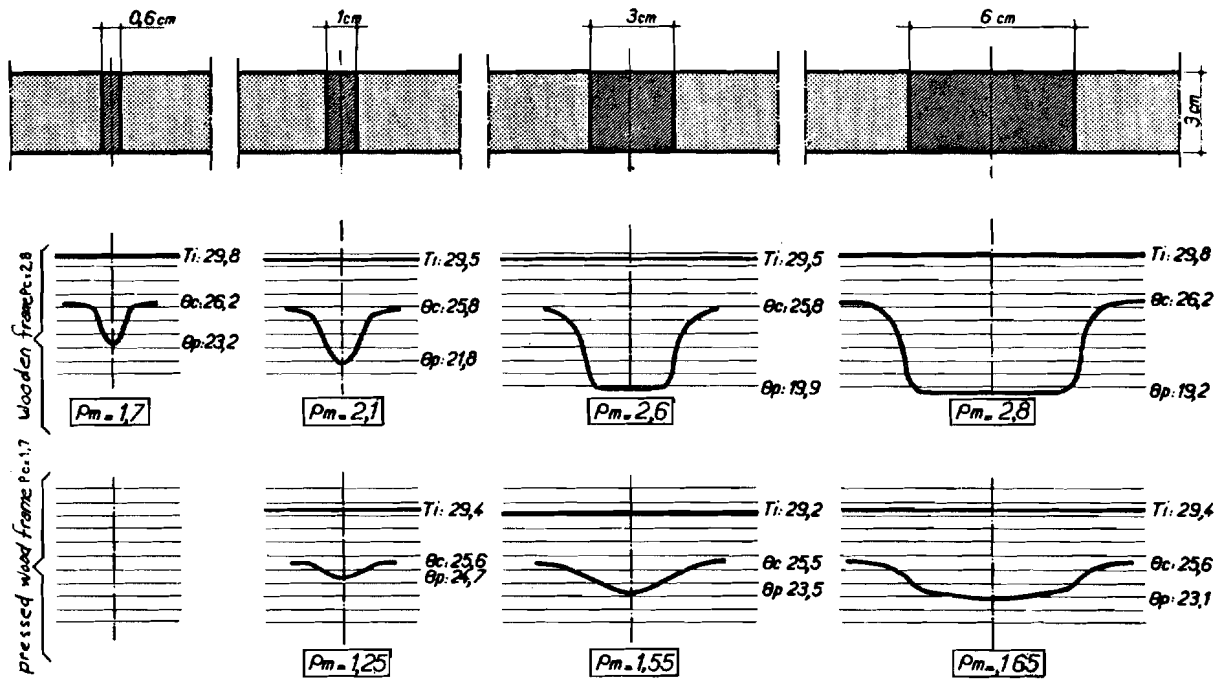

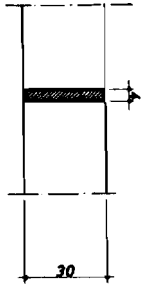
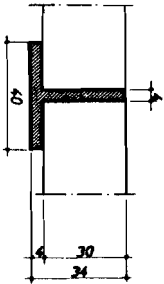
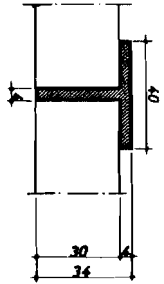
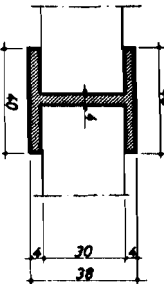
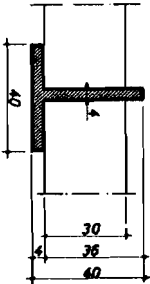
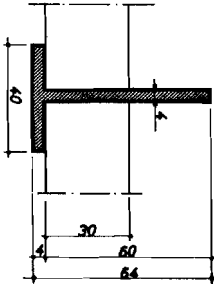
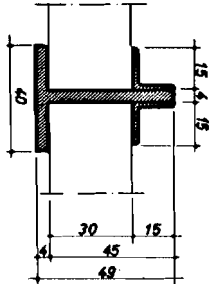
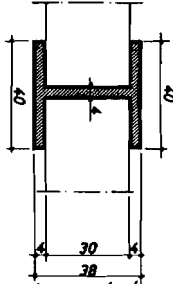
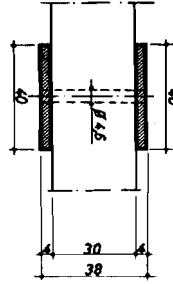
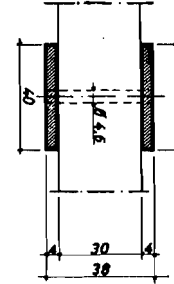
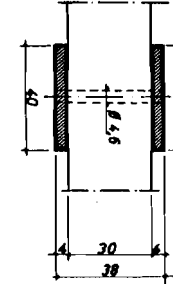

Table V

Light walls: Metal frame
(interior space is to the left)

 Polystyrene
 Iron

TOTAL BRIDGES				
	P_m	5,4	3,1	7,2
μ	0,60	0,35	0,80	0,55
TOTAL BRIDGES WITH EXTERNAL FIN				
	P_m	3,6	5,4	4,9
μ	0,40	0,60	0,55	
INTERRUPTED BRIDGES				
	P_m	4,9	3,9	3,4
μ	0,55	0,44	0,38	0,35

Uninterrupted web $a = 40 \text{ cm}^2$ per metre of section

1 screw every 4 cm $a = 4 \text{ cm}^2/\text{m}$

1 screw every 8 cm $a = 2 \text{ cm}^2/\text{m}$

1 screw every 16 cm $a = 1 \text{ cm}^2/\text{m}$

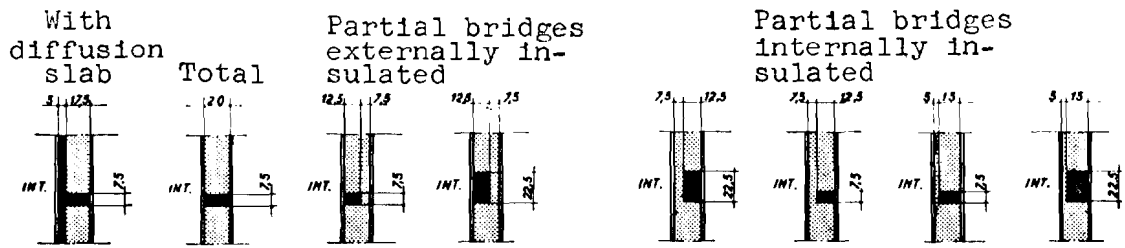

Vertical sections showing horizontal thermal bridges

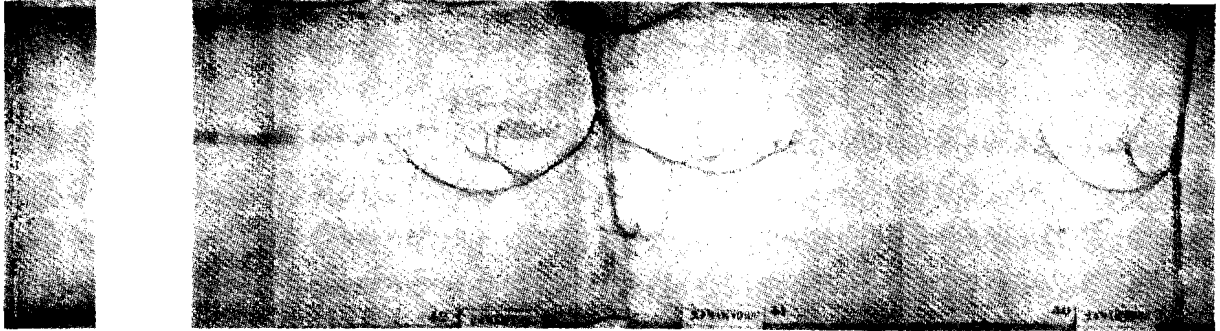

Interior view, condensation on the reactive paint

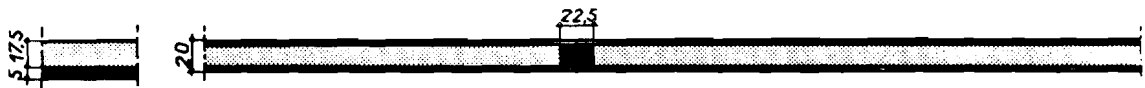

Horizontal section showing the vertical thermal bridge

Fig. 1

Study of thermal bridges

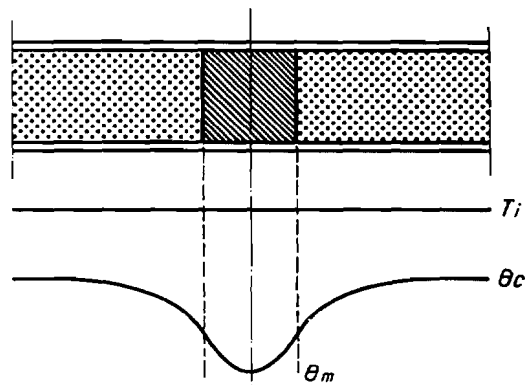
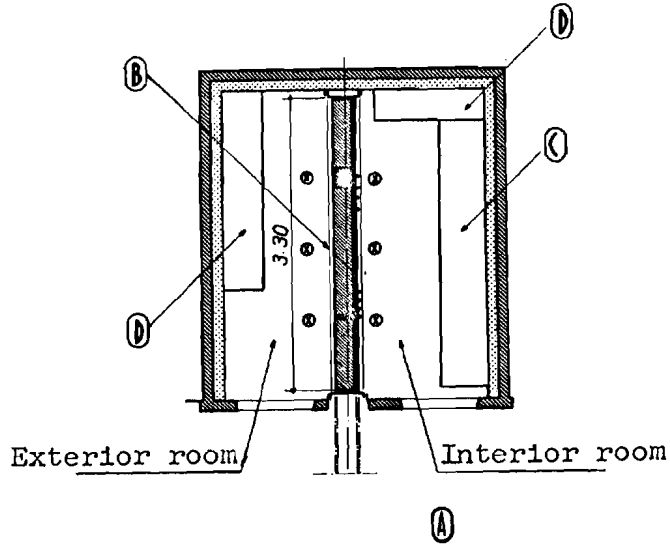

Fig. 2

Distribution of temperature at the surface of a heterogeneous wall



- A - Introduction of wall
- B - Wall under test
- C - Ventilation ducts
- D - Air conditioning unit - hot - cold - humidity
- x - Thermometers
- - Thermocouples

Fig. 3

Plan of thermal room



Fig. 4

Total bridge

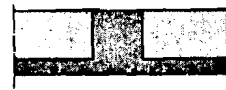

Fig. 5

Thermal bridge with interior diffusion layer



(a)

(b)

Fig. 6

Partial bridge

- {a} Exterior insulation
- {b} Interior insulation



(a)

(b)

Fig. 7

Corrected bridge

- {a} Exterior insulation
- {b} Interior insulation

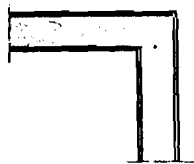

Fig. 8

Corner between two external walls

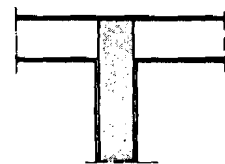

Fig. 9

Partition or floor

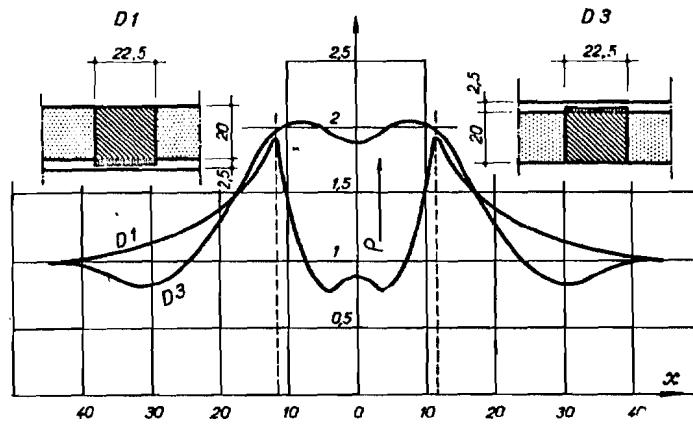

Fig. 10

$\rho(D)$ curves for interior (D_1) or exterior (D_3) insulation

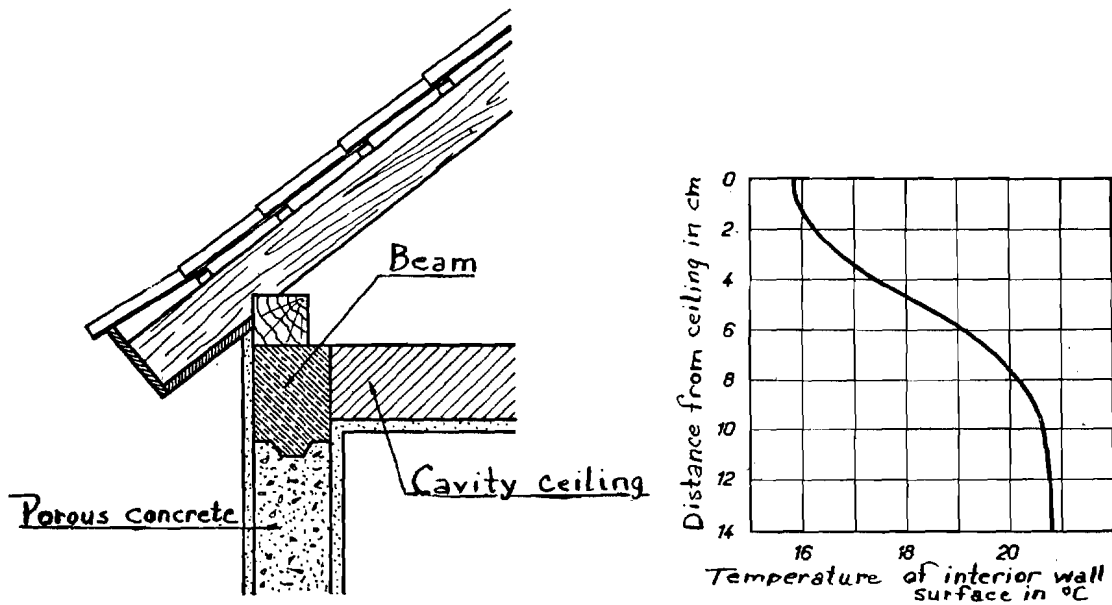

Fig. 11

Distribution of temperatures at the surface of a wall near a thermal bridge produced by the corner of a wall and an attic floor and the beam between them⁽⁸⁾

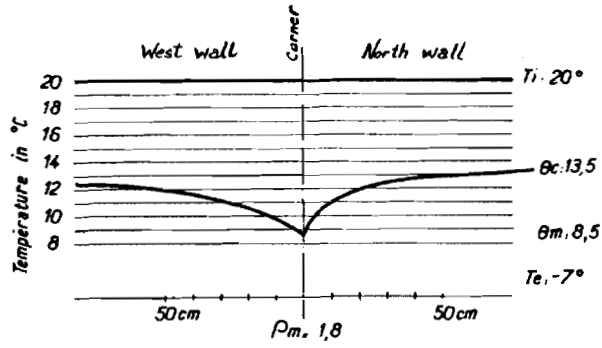

Fig. 12

Temperature curves at the corner between two homogeneous external walls (7)

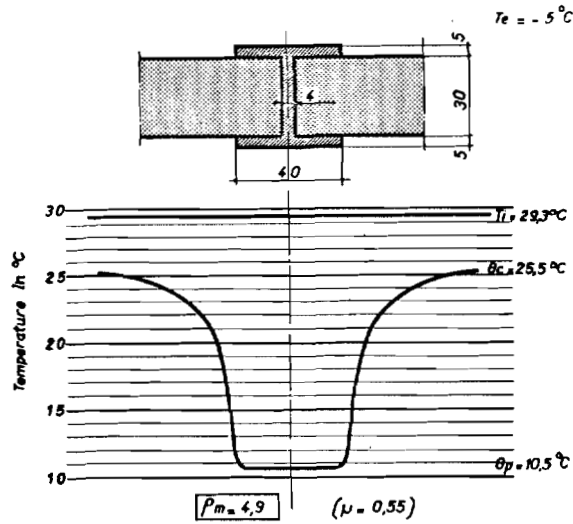

Fig. 13

Light wall - Total bridge - Metal frame

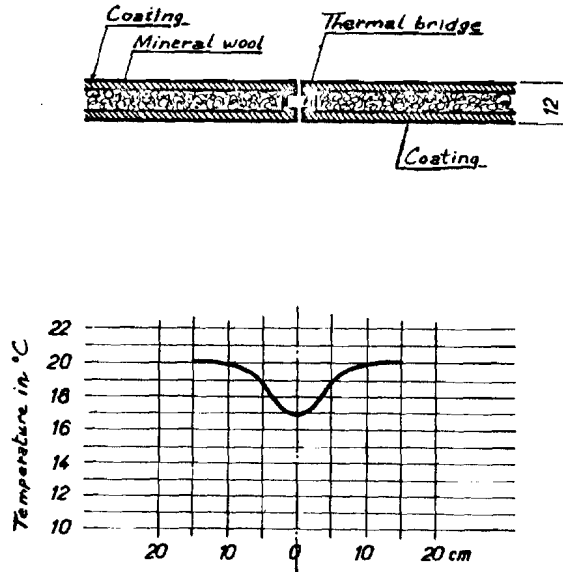

Fig. 14

Distribution of temperatures on the interior surface of a wall close to a thermal bridge produced by a metal frame in the interior of a light panel. Note the diffusion obtained by the interior coating. Nevertheless the thermal bridge is very evident⁽⁸⁾

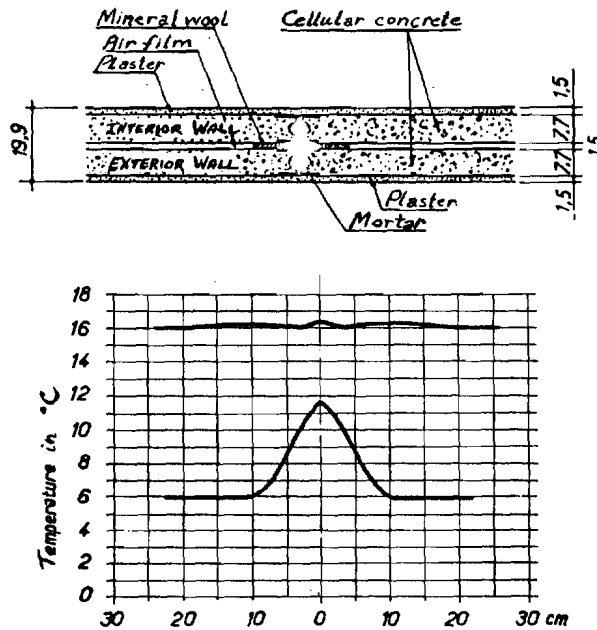

Fig. 15

Distribution of temperatures on the interior surface of the exterior wall, lower curve; and on the interior surface of the interior wall, upper curve. Note the good correction of the thermal bridge by complete interruption of the two frames by a good insulator⁽⁸⁾

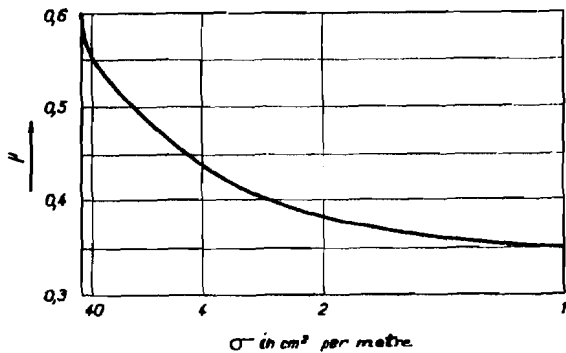

Fig. 16

Interrupted bridge. Value of σ is in terms of the path cross-sectional area

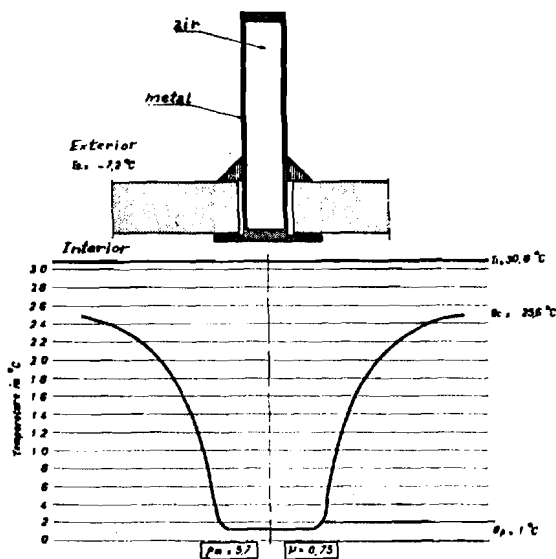

Fig. 17

Light wall. Total bridge with fin

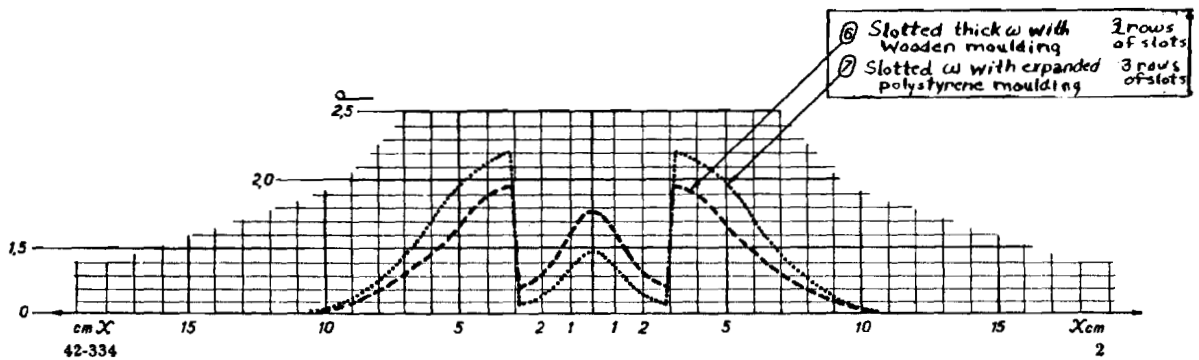
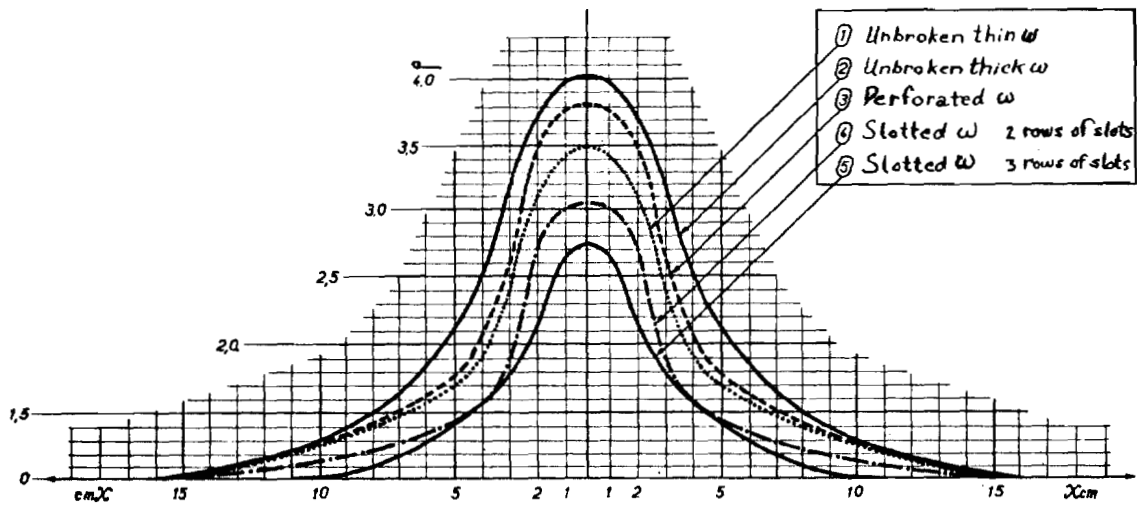
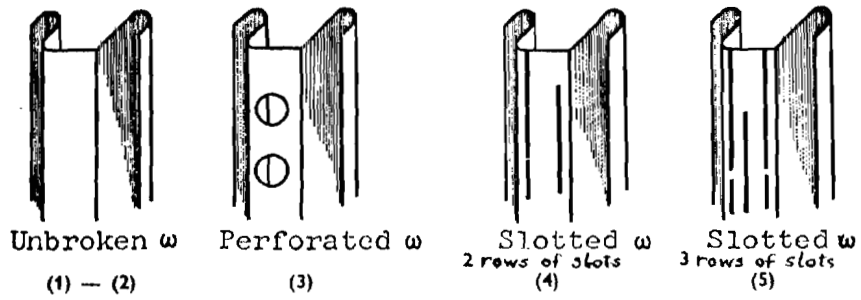
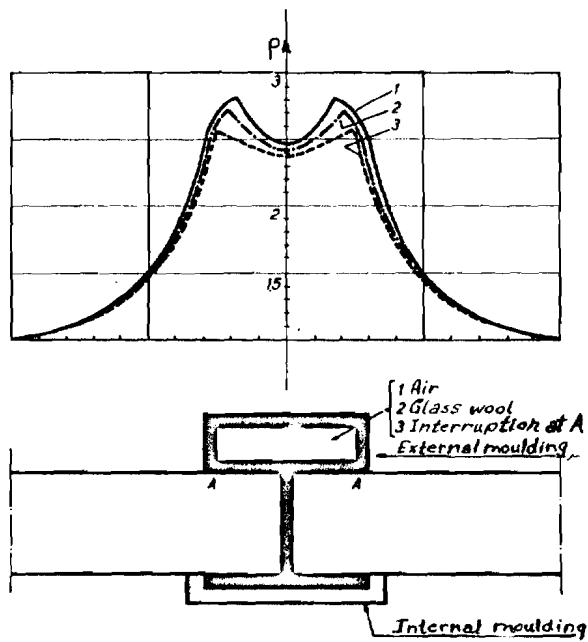

Fig. 18

Light wall. Total bridge. Practical example of correction by interruption of the cold bridge and by interior moulding



1. Joint by itself
2. Filled with glass wool
3. With insulation at A

Fig. 19

Light walls. Metal frame. Practical example of correction by interior and exterior moulding